

FC-FCT Series

2

Centrifugal pumps with in-line suction and delivery flanges, single (FC) and twin (FCT) versions.

Pump body in cast iron and impeller in AISI 316* stainless steel. Designed to pump hot, cold and moderately aggressive liquids.

Models:

FCE-FCTE Close-coupled with special motor shaft extension.

FCS-FCTS With stub shaft and standard motor.

Specifications

Delivery: up to 190 m³/h (2 poles)

up to 330 m³/h (4 poles)

Head: up to 89 m (2 poles)

up to 35 m (4 poles)

Power supply: three-phase and

single-phase 50 and 60 Hz

Power: 0.25 kW to 22 kW

Maximum operating pressure:

10 bar PN10 ("E" versions)

16 bar PN16 ("S" versions)

Temperature of pumped liquid:

-10°C to +130°C ("E" versions)

-20°C to +140°C ("S" versions)

Insulation class: 155 (F)

Protection: IP55

* Check material table for availability

Materials

Pump body: Cast iron

Impeller: Stainless steel (for models

FC40, 50, 65, 80-125, 80-160)

Cast iron for other sizes

Adapter: Aluminium or Cast iron

Mechanical seal:

Carbon/Ceramic/EPDM

Silicon-carbide/Carbon/EPDM

Elastomers: EPDM

Applications

Water supply

Heating, ventilation

Cooling and chilling

General industry

Heat recovery, auxiliary equipment

Available on request: version with Hydrovar frequency converter; FCS with efficiency class 1 motor; version with bronze impeller



For a complete list of technical information, consult www.lowara.com

List of FC SERIES 50 Hz models

FC-FCT (2 poles)

SIZE	kW	VERSION		
		FCEM FCTEM	FCE FCTE	FCS FCTS
40-125/07	0,75	•	•	•
40-125/11	1,1	•	•	•
40-160/15	1,5	•	•	•
40-160/22	2,2	•	•	•
40-200/30	3	-	-	•
40-200/40A	4	-	•	-
40-200/40	4	-	•	•
40-200/55	5,5	-	•	•
40-250/75	7,5	-	•	•
40-250/110	11	-	•	•
50-125/11	1,1	•	•	•
50-125/15	1,5	•	•	•
50-160/22	2,2	•	•	•
50-160/30	3	-	•	•
50-160/40	4	-	•	•
50-200/55	5,5	-	•	•
50-200/75	7,5	-	•	•
50-250/92	9,2	-	•	-
50-250/110A	11	-	-	•
50-250/110	11	-	•	•
50-250/150	15	-	•	•
65-125/22	2,2	•	•	•
65-125/30	3	-	•	•
65-125/40	4	-	•	•
65-160/55	5,5	-	•	•
65-160/75	7,5	-	•	•
65-200/92	9,2	-	•	-
65-200/110A	11	-	-	•
65-200/110	11	-	•	•
65-250/150	15	-	•	•
65-250/185	18,5	-	•	•
65-250/220	22	-	•	•
80-125/30	3	-	•	•
80-125/40	4	-	•	•
80-125/55	5,5	-	•	•
80-160/75	7,5	-	•	•
80-200/110	11	-	•	•
80-200/150	15	-	•	•
80-200/185	18,5	-	•	•
80-200/220	22	-	•	•
100-160/110	11	-	•	•
100-200/185	18,5	-	•	•
100-200/220	22	-	•	•

• = Available

fc_fce-fcs_2p50_b_tem

FC.4-FCT.4 (4 poles)

SIZE	kW	VERSION		
		FCE4 FCTE4	FCS4	FCTS4
40-125/02A	0,25	•	-	-
40-125/02	0,25	•	-	-
40-160/02	0,25	•	-	-
40-160/03	0,37	•	-	-
40-200/05	0,55	•	•	•
40-200/07	0,75	•	•	•
40-250/11	1,1	•	•	•
40-250/15	1,5	•	•	•
50-125/02	0,25	•	-	-
50-125/03	0,37	•	-	-
50-160/05	0,55	•	-	-
50-200/07	0,75	•	•	•
50-200/11	1,1	•	•	•
50-250/15	1,5	•	•	•
50-250/22	2,2	•	•	•
65-125/03	0,37	•	-	-
65-125/05	0,55	•	-	-
65-160/07	0,75	•	•	•
65-160/11	1,1	•	•	•
65-200/15	1,5	•	•	•
65-250/22	2,2	•	•	•
65-250/30	3	•	•	•
80-125/07	0,75	•	•	•
80-125/11	1,1	•	•	•
80-200/15	1,5	•	•	•
80-200/22	2,2	•	•	•
80-200/30	3	•	•	•
80-250/40	4	•	•	•
80-250/55	5,5	•	•	•
100-160/15	1,5	•	•	•
100-200/22	2,2	•	•	•
100-200/30	3	•	•	•
100-250/40	4	•	•	•
100-250/55	5,5	•	•	•
100-250/75	7,5	•	•	•
125-160/30	3	-	•	•
125-200/40	4	-	•	•
125-200/55	5,5	-	•	•
125-250/75	7,5	-	•	•
125-250/110	11	-	•	•
125-315/150	15	-	•	-
125-315/185	18,5	-	•	-
125-315/220	22	-	•	-
150-200/55	5,5	-	•	•
150-200/75	7,5	-	•	•
150-250/110	11	-	•	•
150-250/150	15	-	•	•
150-250/185	18,5	-	•	•

• = Available

fc_fce4-fcs4_4p50_b_tem

FCE-FCS SERIES

Hydraulic performance table at 50 Hz, 2 poles

2

PUMP TYPE	RATED POWER		Q = DELIVERY																		
			l/min	100	200	350	375	400	600	700	800	850	1000	1200	1300	1500	1600	1750	1950	2500	3000
			m ³ /h	0	6	12	21	22,5	24	36	42	48	51	60	72	78	90	96	105	117	150
kW		HP		H = TOTAL HEAD METRES COLUMN OF WATER																	
40-125/07	0,75	1	17,1	15,1	11,8	3,6															
40-125/11	1,1	1,5	22,6	20,2	16,7	8,8	7,0														
40-160/15	1,5	2	27,3	24,7	20,9	13,1	11,3	9,3													
40-160/22	2,2	3	35,3	32,6	28,8	21,1	19,5	17,7													
40-200/*	*	*	42,5	38,9	34,0																
40-200/40	4	5,5	51,0	46,9	41,7	30,6															
40-200/55	5,5	7,5	62,0	57,6	51,3	39,6	37,1														
40-250/75	7,5	10	75,4	71,1	65,0	52,9	50,3														
40-250/110	11	15	85,2	80,8	74,8	62,3	59,6	56,6													
50-125/11/A	1,1	1,5	15,3		13,5	11,1	10,6	10,1	5,4												
50-125/15/A	1,5	2	19,1		17,5	14,9	14,4	13,8	8,6	5,5											
50-160/22	2,2	3	26,1		23,9	21,1	20,5	20,0	14,7	11,6											
50-160/30	3	4	32,8		30,6	27,2	26,5	25,9	19,9	16,6	13,1										
50-160/40	4	5,5	38,1		36,1	32,9	32,3	31,6	25,1	21,3	17,3	15,3									
50-200/55	5,5	7,5	47,0		43,5	39,6	38,8	38,0	30,3												
50-200/75	7,5	10	56,0		52,0	48,2	47,5	46,7	39,4	34,9											
50-250/**	**	**	63,2		59,4	55,3	54,5	53,8	46,7	42,6	38,0										
50-250/110	11	15	69,4		65,3	61,3	60,6	59,8	53,2	49,4	45,0	42,5									
50-250/150	15	20	83,0		79,2	75,1	74,4	73,6	66,1	61,6	56,6	53,9									
65-125/22	2,2	3	18,8					16,4	14,3	13,0	11,4	10,6	7,9								
65-125/30	3	4	22,9					20,3	18,1	16,7	15,2	14,3	11,6								
65-125/40	4	5,5	26,6					24,4	22,4	21,1	19,7	18,9	16,3	12,1							
65-160/55	5,5	7,5	35,1					32,5	30,1	28,7	27,1	26,3	23,5	19,1							
65-160/75	7,5	10	42,4					40,0	37,4	35,8	34,0	33,1	29,9	25,2	22,5						
65-200/**	**	**	53,0					47,6	44,1	42,2	40,1	39,0	35,2	28,4	24,0						
65-200/110	11	15	61,0					55,2	51,3	49,3	47,1	45,9	42,1	35,8	31,8						
65-250/150	15	20	70,0					66,3	63,0	61,1	58,9	57,8	54,2	48,9	46,1	40,0					
65-250/185	18,5	25	80,0					75,2	71,8	69,9	67,7	66,6	63,0	57,6	54,6	47,9					
65-250/220	22	30	89,0					84,3	80,7	78,7	76,5	75,3	71,6	66,0	63,0	56,3	52,6				
80-125/30	3	4	15,5					14,5	14,1	13,6	13,3	12,3	10,7	9,9							
80-125/40	4	5,5	19,0					18,0	17,6	17,0	16,8	15,8	14,2	13,3	11,5						
80-125/55	5,5	7,5	23,0					21,5	21,0	20,5	20,2	19,3	18,0	17,2	15,5	14,5					
80-160/75	7,5	10	28,0					26,5	26,1	25,6	25,4	24,7	23,6	23,0	21,6	20,8	19,5				
80-200/110	11	15	41,0					37,0	36,2	35,2	34,7	33,2	30,7	29,3	26,2	24,5	21,5				
80-200/150	15	20	49,4					46,3	45,6	44,8	44,3	43,0	41,0	39,9	37,5	36,2	33,9	30,5			
80-200/185	18,5	25	56,9					53,4	52,6	51,7	51,2	49,8	47,9	46,9	44,7	43,5	41,4	38,1			
80-200/220	22	30	65,2					61,3	60,4	59,5	59,0	57,6	55,5	54,5	52,2	51,0	49,1	46,0			
100-160/110	11	15	29,0										28,0	27,3	26,9	25,9	25,4	24,6	23,4	19,5	
100-200/185	18,5	25	45,0											39,5	38,8	37,5	36,8	35,9	34,5	30,4	25,0
100-200/220	22	30	53,0											48,0	47,3	46,0	45,3	44,3	42,9	38,7	33,6

* FCE40-200/40A : 4 (kW) - 5.5 (HP)

FCS40-200/30 : 3 (kW) - 4 (HP)

fce-fcs-2p50-en_d_th

** FCE50-250/92 : 9.2 (kW) - 12.5 (HP)

FCS50-250/110A : 11 (kW) - 15 (HP)

FCE65-200/92 : 9.2 (kW) - 12.5 (HP)

FCS65-200/110A : 11 (kW) - 15 (HP)

Performances according to ISO 9906 - Annex A

FCE4-FCS4 SERIES

Hydraulic performance table at 50 Hz, 4 poles

PUMP TYPE	RATED POWER		Q = DELIVERY																						
	kW	HP	l/min	50	100	150	175	200	300	350	400	500	600	650	750	900	1100	1200	1500	1800	2000	2500			
			m ³ /h	0	3	6	9	10,5	12	18	21	24	30	36	39	45	54	66	72	90	108	120	150		
H = TOTAL HEAD METRES COLUMN OF WATER																									
40-125/02A *	0,25	0,33	4,7	4,1	3,3	2,0																			
40-125/02 *	0,25	0,33	5,9	5,3	4,5	3,3	2,5																		
40-160/02 *	0,25	0,33	7,1	6,4	5,5	4,3	3,6	2,6																	
40-160/03 *	0,37	0,5	8,9	8,1	7,2	6,0	5,2	4,4																	
40-200/05	0,55	0,75	12,4	11,4	10,1	8,2	7,1																		
40-200/07	0,75	1	14,2	13,2	11,9	10,1	9,1	7,9																	
40-250/11	1,1	1,5	18,6	17,3	15,7	13,9	12,8	11,6																	
40-250/15	1,5	2	21,0	19,8	18,2	16,4	15,4	14,3																	
50-125/02 *	0,25	0,33	6,2		5,5	5,0	4,6	4,3	2,7	1,8															
50-125/03 *	0,37	0,5	8,0		7,4	6,8	6,5	6,1	4,4	3,5	2,5														
50-160/05 *	0,55	0,75	9,4		8,8	8,2	7,9	7,5	5,9	4,9	3,9														
50-200/07	0,75	1	11,4		10,5	9,9	9,5	9,1	7,1	5,6	3,7														
50-200/11	1,1	1,5	13,6		12,6	12,0	11,6	11,2	9,2	7,8	5,9														
50-250/15	1,5	2	17,0		15,9	15,2	14,8	14,4	12,5	11,4	10,1	7,0													
50-250/22	2,2	3	20,2		18,9	18,2	17,8	17,4	15,5	14,3	13,0	10,0													
65-125/03 *	0,37	0,5	5,6					4,9	4,3	3,9	3,5	2,6													
65-125/05 *	0,55	0,75	6,7					5,9	5,4	5,1	4,7	3,9	2,8	2,2											
65-160/07	0,75	1	8,6					7,8	7,2	6,8	6,4	5,4	4,3	3,7	2,4										
65-160/11	1,1	1,5	10,4					9,7	9,0	8,6	8,2	7,2	5,9	5,3	3,8										
65-200/15	1,5	2	14,7					13,2	12,1	11,6	11,0	9,7	8,1	7,0	4,2										
65-250/22	2,2	3	19,0					17,6	16,6	16,0	15,4	14,1	12,7	11,9	10,1	6,5									
65-250/30	3	4	21,4					20,1	19,1	18,5	17,9	16,6	15,2	14,4	12,6	9,4									
80-125/07	0,75	1	5,6						5,2	5,1	5,0	4,6	4,3	4,1	3,6	2,8	1,6								
80-125/11	1,1	1,5	6,8						6,4	6,3	6,2	6,0	5,7	5,5	5,1	4,3	3,1	2,5							
80-200/15	1,5	2	10,5						9,6	9,4	9,2	8,7	8,1	7,8	7,1	5,8	3,3								
80-200/22	2,2	3	13,7						12,7	12,5	12,3	11,9	11,3	11,0	10,3	9,0	6,8	5,4							
80-200/30	3	4	15,8						14,7	14,5	14,3	13,8	13,3	13,0	12,4	11,2	9,3	8,1							
80-250/40	4	5,5	19,9						18,7	18,5	18,2	17,7	17,0	16,7	15,9	14,6	12,5	11,2							
80-250/55	5,5	7,5	23,2						22,0	21,8	21,5	21,0	20,3	20,0	19,3	18,0	16,0	14,8	10,4						
100-160/15	1,5	2	7,8								7,4	7,2	7,1	6,9	6,5	6,0	5,6	4,5	3,0						
100-200/22	2,2	3	10,5									9,3	9,2	8,9	8,3	7,5	7,1	5,4	3,5	2,0					
100-200/30	3	4	12,8										11,5	11,4	11,1	10,6	9,8	9,3	7,8	5,8	4,3				
100-250/40	4	5,5	17,0											15,5	15,3	14,9	14,3	13,4	12,9	11,2	9,2	7,8			
100-250/55	5,5	7,5	20,5												19,0	18,8	18,4	17,8	17,0	16,5	14,9	13,1	11,8	8,0	
100-250/75	7,5	10	24,0													22,5	22,3	22,0	21,5	20,7	20,3	18,8	17,1	15,8	11,9

* FCE4 VERSION ONLY

fce4-fcs4-4p50-en_f_th

Performances according to ISO 9906 - Annex A

FCS4 SERIES

Hydraulic performance table at 50 Hz, 4 poles

2

PUMP TYPE	RATED POWER		Q = DELIVERY																	
	kW	HP	l/min 0	1000	1083	1167	1333	1500	1667	2000	2333	2667	3000	3333	3667	4167	4667	5000	5333	5500
			m ³ /h 0	60	65	70	80	90	100	120	140	160	180	200	220	250	280	300	320	330
H = TOTAL HEAD METRES COLUMN OF WATER																				
125-160/30	3	4	10,5	9,2	9,0	8,8	8,3	7,9	7,4	6,3	5,2	3,7	2,0							
125-200/40	4	5,5	12,7	11,5	11,3	11,0	10,5	9,9	9,3	7,7	5,7	3,4								
125-200/55	5,5	7,5	15,6	14,6	14,4	14,3	13,9	13,4	12,9	11,6	10,0	8,0	5,5							
125-250/75	7,5	10	20,5	19,1	18,9	18,6	18,1	17,4	16,6	14,7	12,4	9,6	6,7							
125-250/110	11	15	26,1	24,8	24,6	24,4	23,9	23,4	22,7	21,1	19,2	16,8	14,0	10,7	7,1					
125-315/150	15	20	27,0	26,0	25,9	25,7	25,4	25,0	24,6	23,5	22,1	20,4	18,3	15,9	12,9	7,8				
125-315/185	18,5	25	31,0	30,0	29,9	29,8	29,5	29,2	28,9	28,0	26,7	25,1	23,1	20,7	18,0	13,3	8,0			
125-315/220	22	30	35,0	34,0	33,9	33,8	33,6	33,3	32,9	32,1	30,9	29,5	27,6	25,5	22,9	18,4	12,9	8,8		
150-200/55	5,5	7,5	12,0	10,5	10,4	10,2	9,9	9,6	9,3	8,6	7,9	7,2	6,4	5,7	4,8	3,2				
150-200/75	7,5	10	16,0	14,8	14,6	14,4	14,1	13,7	13,4	12,6	11,9	11,1	10,3	9,5	8,6	6,9	4,7			
150-250/110	11	15	18,4					17,8	17,6	17,0	16,3	15,5	14,6	13,5	12,3	10,2	7,7	5,8		
150-250/150	15	20	22,4					22,0	21,8	21,3	20,7	20,0	19,3	18,4	17,4	15,6	13,3	11,5	9,5	8,3
150-250/185	18,5	25	25,1					24,7	24,6	24,1	23,6	23,0	22,2	21,3	20,3	18,5	16,4	14,7	13,0	12,0

Performances according to ISO 9906 - Annex A

fcs4-4p50-en_d_th

Black and white technical books available
see www.lowara.it

FCE-FCS SERIES

Operating characteristics at 50 Hz, 2 poles

2

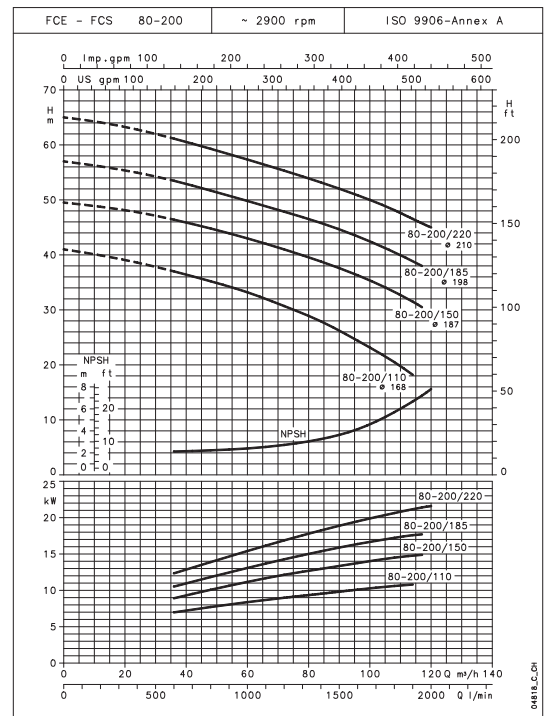
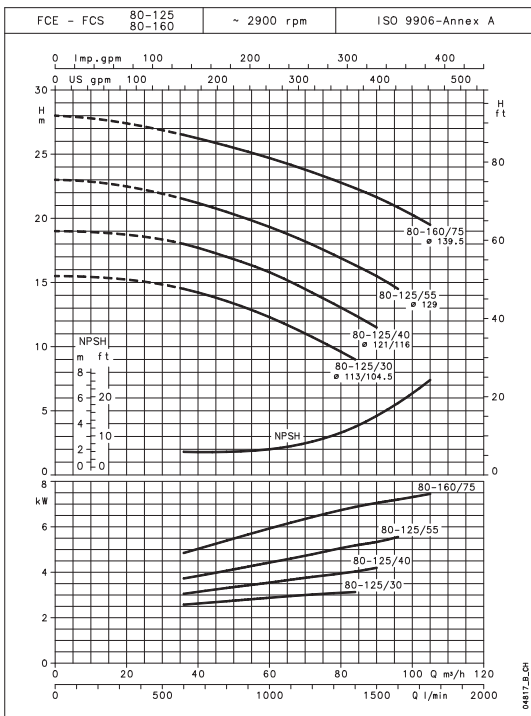
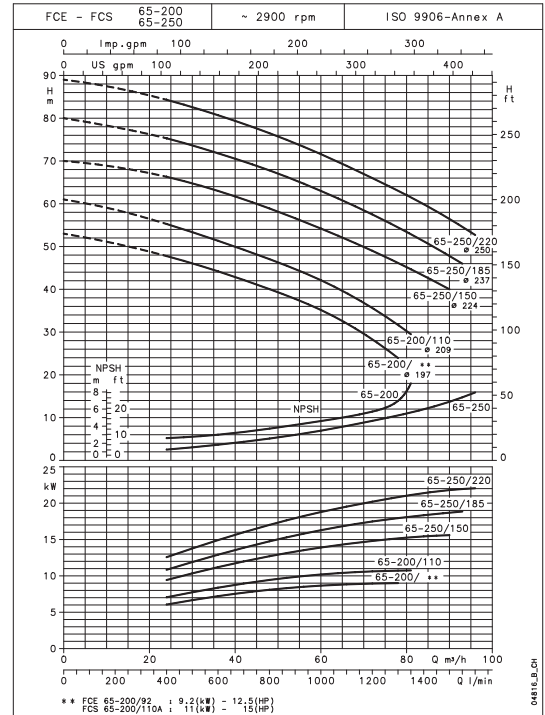
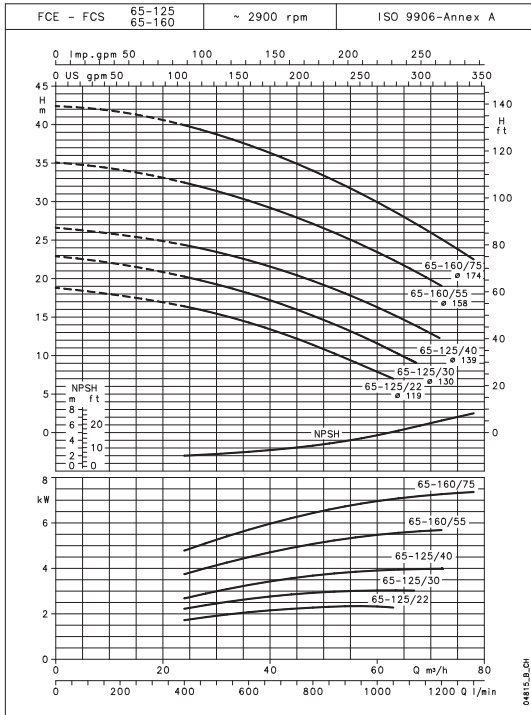

These NPSH values are valid in laboratory conditions; for practical purposes, values should be increased by a 0.5 m safety margin.

These performances are valid for liquids with density $\rho = 1.0 \text{ kg/dm}^3$ and kinematic viscosity $\nu = 1 \text{ mm}^2/\text{s}$.

FCE-FCS SERIES

Operating characteristics at 50 Hz, 2 poles

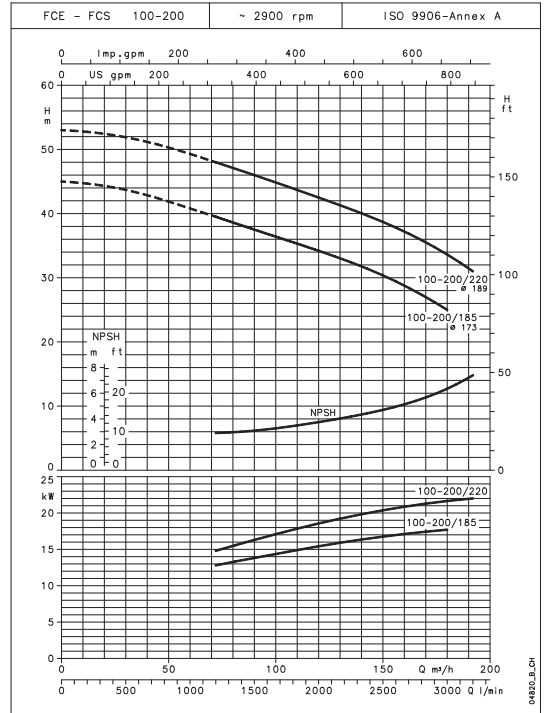
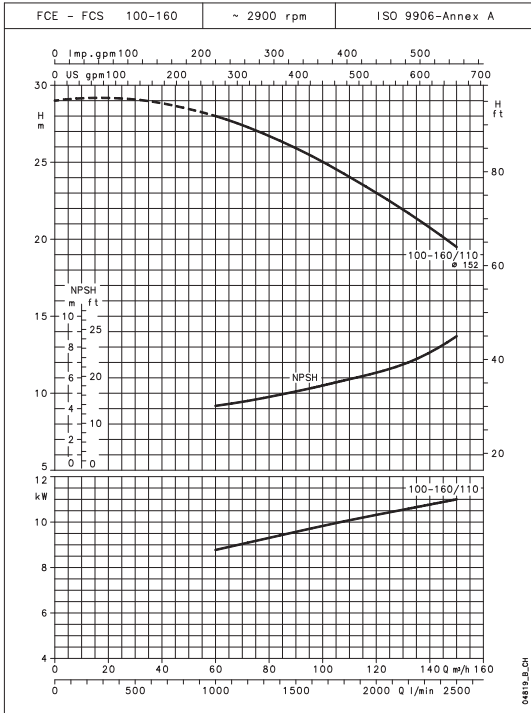

These NPSH values are valid in laboratory conditions; for practical purposes, values should be increased by a 0.5 m safety margin.

These performances are valid for liquids with density $\rho = 1.0 \text{ kg/dm}^3$ and kinematic viscosity $\nu = 1 \text{ mm}^2/\text{s}$.

FCE4-FCS4 SERIES

Operating characteristics at 50 Hz, 4 poles

2

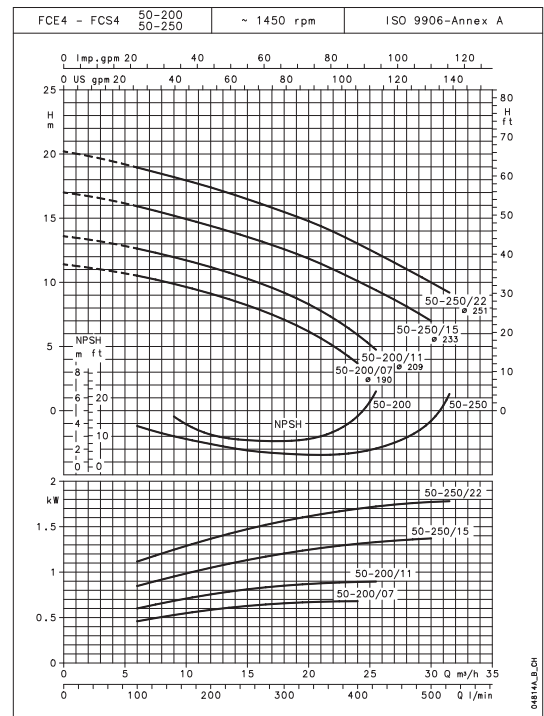
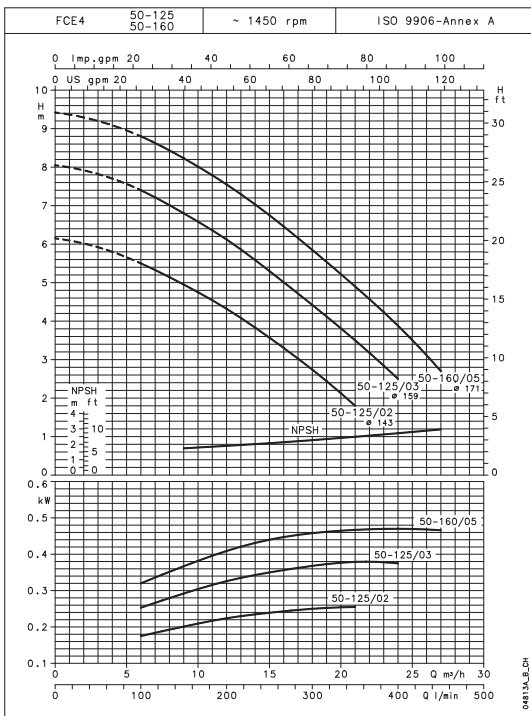
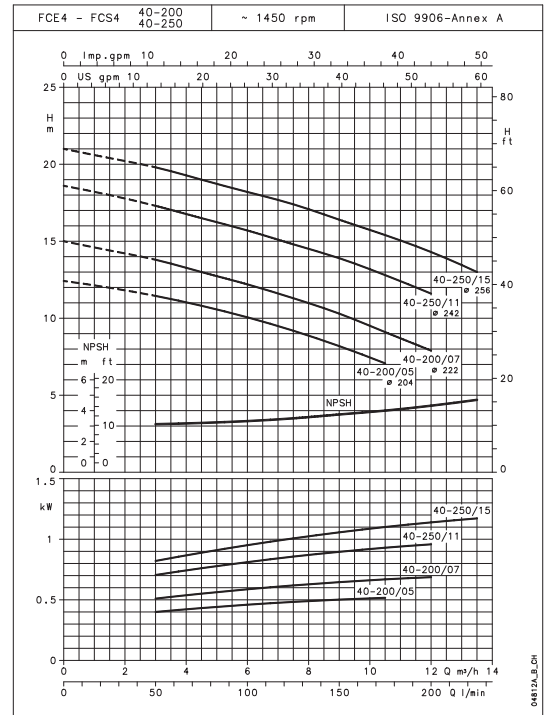
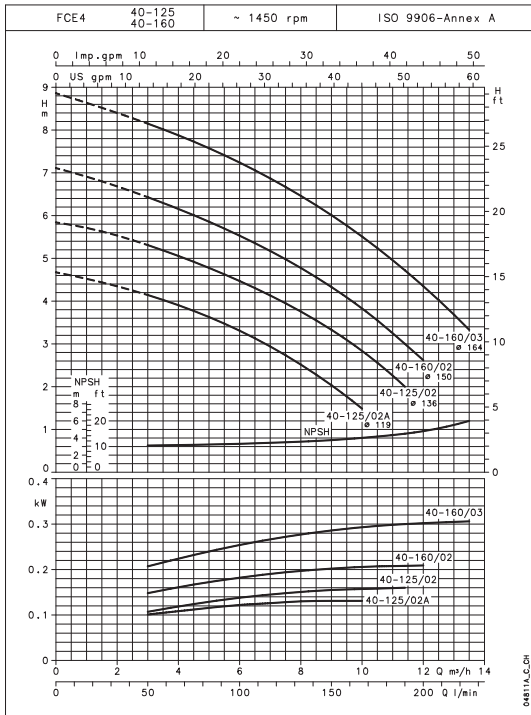

These NPSH values are valid in laboratory conditions; for practical purposes, values should be increased by a 0.5 m safety margin.

These performances are valid for liquids with density $\rho = 1.0 \text{ kg/dm}^3$ and kinematic viscosity $\nu = 1 \text{ mm}^2/\text{s}$.

FCE4-FCS4 SERIES

Operating characteristics at 50 Hz, 4 poles

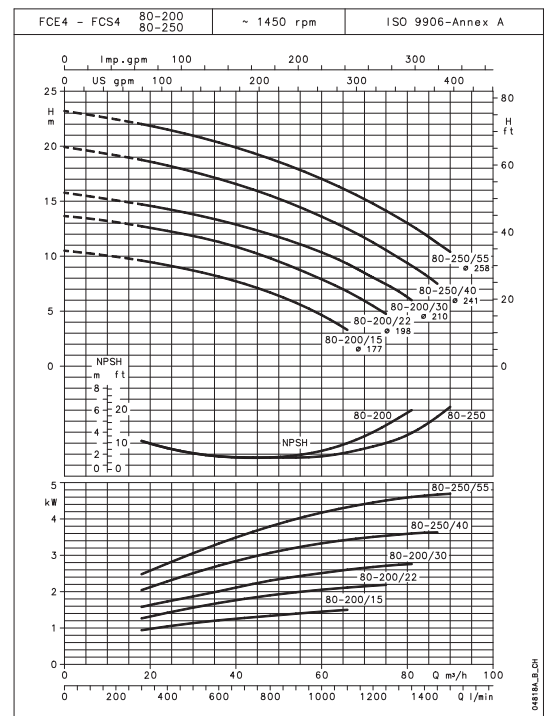
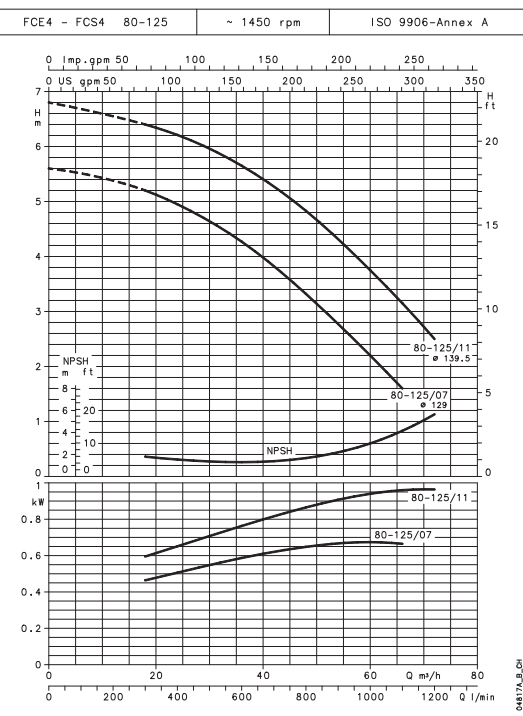
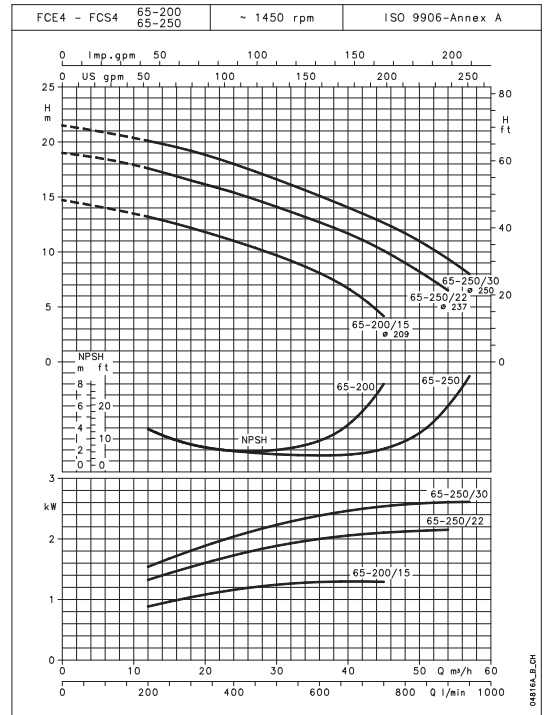
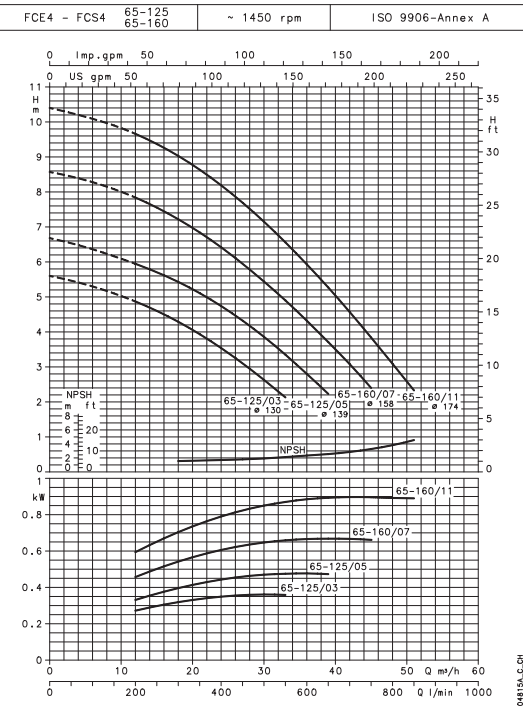

These NPSH values are valid in laboratory conditions; for practical purposes, values should be increased by a 0.5 m safety margin.

These performances are valid for liquids with density $\rho = 1.0 \text{ kg/dm}^3$ and kinematic viscosity $\nu = 1 \text{ mm}^2/\text{s}$.

FCE4-FCS4 SERIES

Operating characteristics at 50 Hz, 4 poles

2

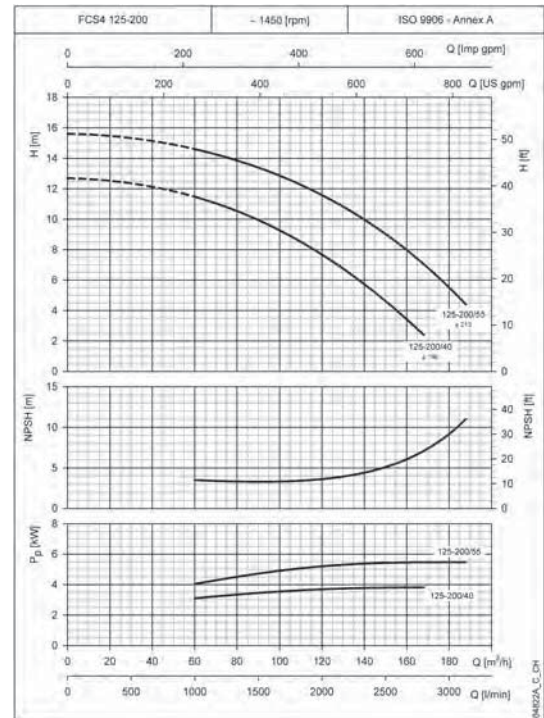
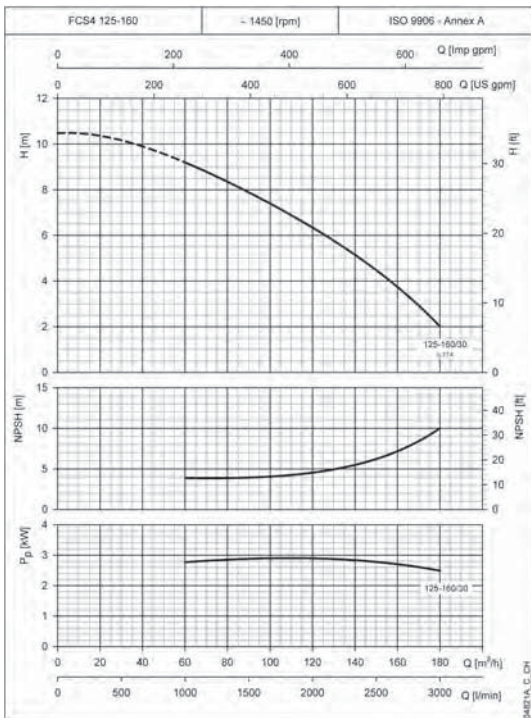
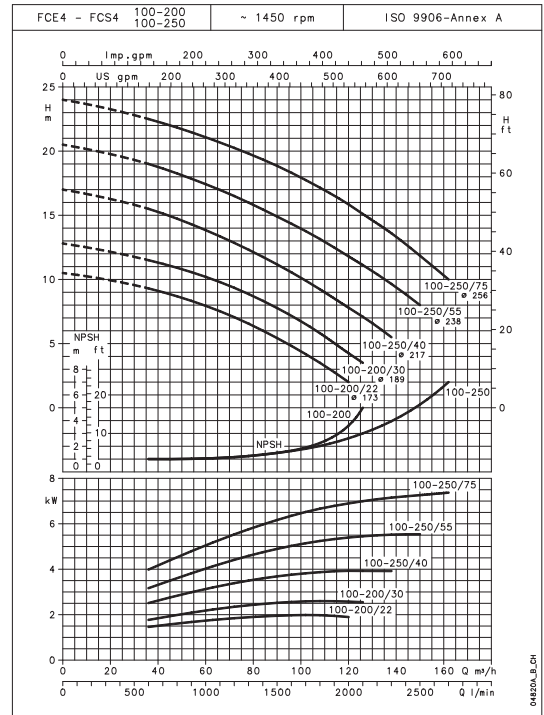
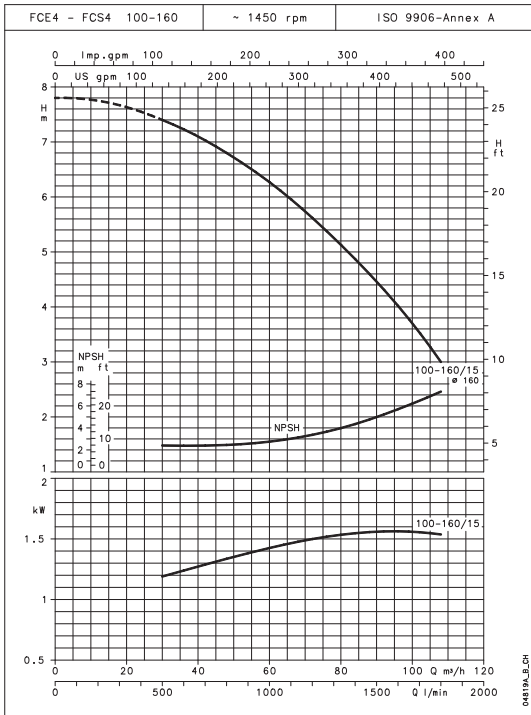

These NPSH values are valid in laboratory conditions; for practical purposes, values should be increased by a 0.5 m safety margin.

These performances are valid for liquids with density $\rho = 1.0 \text{ kg/dm}^3$ and kinematic viscosity $\nu = 1 \text{ mm}^2/\text{s}$.

FCS4 SERIES

Operating characteristics at 50 Hz, 4 poles

2

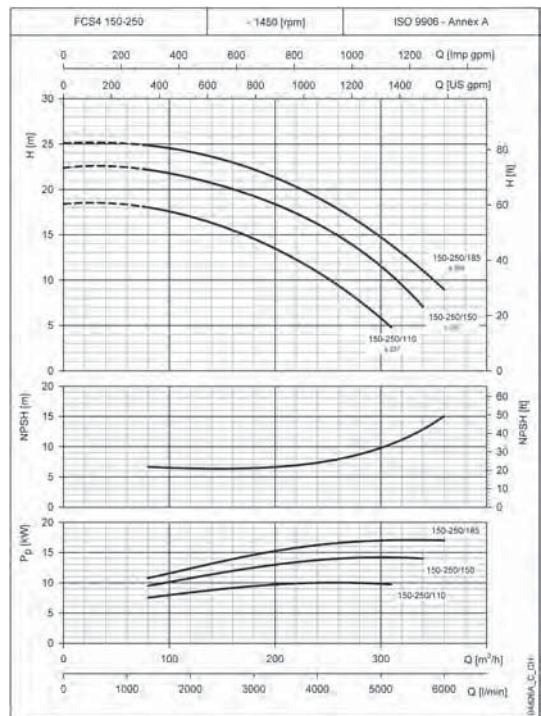
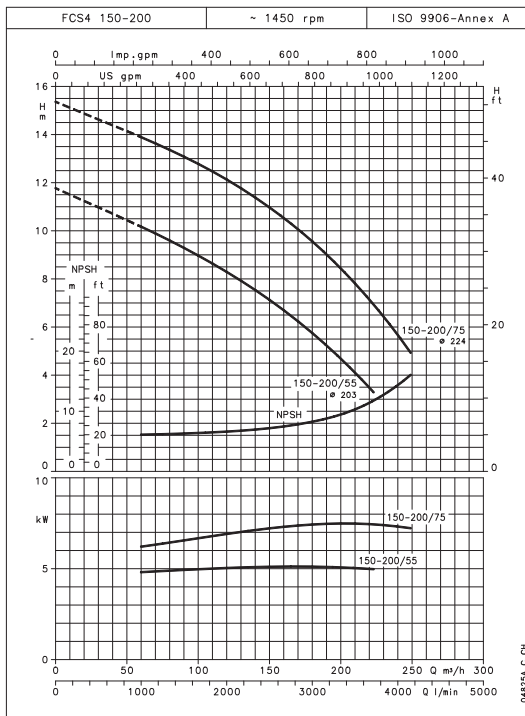
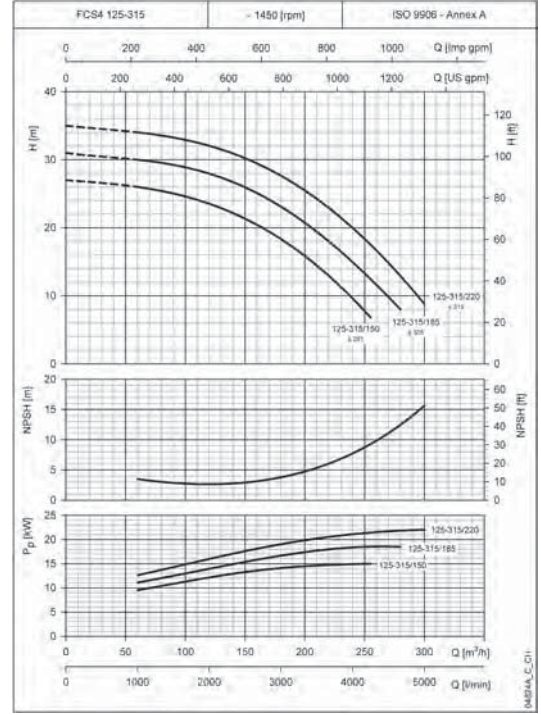
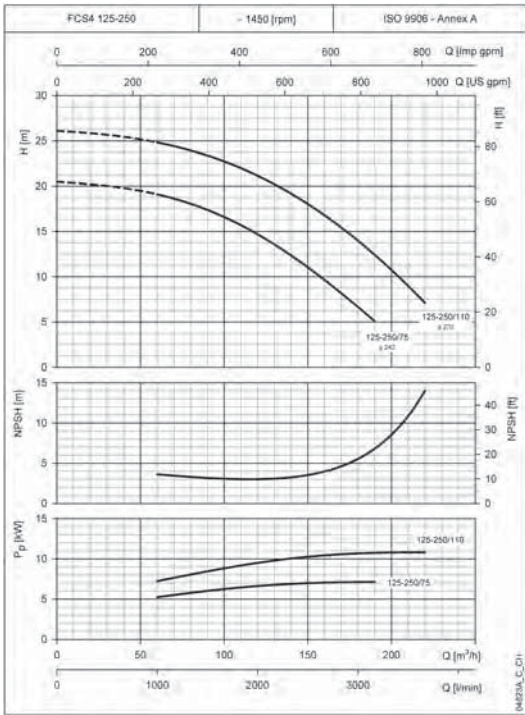

These NPSH values are valid in laboratory conditions; for practical purposes, values should be increased by a 0.5 m safety margin.

These performances are valid for liquids with density $\rho = 1.0 \text{ kg/dm}^3$ and kinematic viscosity $\nu = 1 \text{ mm}^2/\text{s}$.

FCTE-FCTS SERIES (SINGLE OPERATION)

Hydraulic performance table at 50 Hz, 2 poles

2

PUMP TYPE	RATED POWER		Q = DELIVERY																		
	kW	HP	l/min	100	200	300	350	400	600	700	900	1000	1200	1300	1400	1600	1750	2000	2500	3000	
			m ³ /h	6	12	18	21	24	36	42	54	60	72	78	84	96	105	120	150	180	
H = TOTAL HEAD IN COLUMN OF WATER (METRES)																					
40-125/07	0,75	1	17,9	16,0	12,5	7,4	4,3														
40-125/11	1,1	1,5	22,6	20,4	16,7	11,5	8,3														
40-160/15	1,5	2	28,2	26,0	22,3	17,2	14,1	10,6													
40-160/22	2,2	3	35,3	33,4	29,5	24,0	20,8	17,4													
40-200/ *	*	*	43,2	39,3	33,9	27,1															
40-200/40	4	5,5	52,4	48,8	43,7	37,0	33,1														
40-200/55	5,5	7,5	61,0	57,4	52,1	45,3	41,4														
40-250/75	7,5	10	75,7	71,4	66,1	59,4	55,3														
40-250/110	11	15	86,2	82,5	76,9	69,7	65,4	60,7													
50-125/11	1,1	1,5	14,4		13,2	11,6	10,5	9,4	4,2												
50-125/15	1,5	2	18,4		17,6	15,9	14,8	13,6	7,9	4,8											
50-160/22	2,2	3	26,2		24,4	22,4	21,3	19,9	13,7	10,1											
50-160/30	3	4	33,1		30,3	28,3	27,1	25,7	19,3	15,4											
50-160/40	4	5,5	39,1		36,6	34,5	33,3	31,9	25,0	20,7											
50-200/55	5,5	7,5	47,9		44,9	42,6	41,2	39,7	31,7												
50-200/75	7,5	10	57,4		54,3	51,9	50,4	48,8	40,5	35,1											
50-250/**	**	**	64,4		60,9	58,7	57,4	56,1	49,2	44,8											
50-250/110	11	15	75,0		71,3	69,0	67,7	66,2	59,2	54,9											
50-250/150	15	20	87,4		83,9	81,6	80,2	78,7	71,5	67,1	56,3										
65-125/22	2,2	3	17,8					16,3	13,9	12,3	8,3	5,9									
65-125/30	3	4	21,8					20,3	17,9	16,3	12,3	10,0									
65-125/40	4	5,5	25,7					24,6	22,5	21,1	17,3	15,1	9,6								
65-160/55	5,5	7,5	34,1					32,8	30,6	29,1	25,2	22,9	17,4								
65-160/75	7,5	10	41,6					39,3	36,7	34,9	30,8	28,3	22,7	19,6							
65-200/**	**	**	52,0					48,7	45,8	43,9	38,9	35,8	28,1	23,4							
65-200/110	11	15	58,8					54,3	51,1	49,1	44,0	40,8	32,7	27,8							
65-250/150	15	20	69,8					65,5	62,7	61,1	56,9	54,4	48,1	44,4	40,1						
65-250/185	18,5	25	78,6					73,7	70,8	69,1	65,0	62,5	56,5	52,9	48,8						
65-250/220	22	30	86,8					82,9	80,1	78,3	74,1	71,5	65,5	62,0	58,1	49,0					
80-125/30	3	4	15,8					14,4	13,8	12,2	11,3	9,3	8,2	7,1							
80-125/40	4	5,5	19,0					17,8	17,3	15,9	15,1	13,3	12,3	11,2							
80-125/55	5,5	7,5	23,6					22,3	21,8	20,7	20,0	18,3	17,4	16,4	14,0						
80-160/75	7,5	10	28,2					26,7	26,3	25,4	24,9	23,5	22,7	21,8	19,7	17,8					
80-200/110	11	15	40,7					38,1	37,5	35,9	35,0	32,9	31,7	30,4	27,5	25,0					
80-200/150	15	20	51,1					48,0	47,3	45,7	44,7	42,6	41,5	40,2	37,3	34,8					
80-200/185	18,5	25	57,2					54,0	53,3	51,8	50,9	49,0	47,8	46,6	43,8	41,4					
80-200/220	22	30	63,9					60,9	60,3	58,8	58,0	56,1	55,0	53,8	51,0	48,6	43,8				
100-160/110	11	15	29,0									27,6	26,8	26,3	25,7	24,5	23,4	21,4	16,5		
100-200/185	18,5	25	39,8										37,9	37,5	37,0	36,0	35,2	33,5	29,5	24,5	
100-200/220	22	30	47,5											45,3	44,9	44,4	43,4	42,5	40,8	36,7	31,6

* FCTE 40-200/40A : 4 [kW] - 5.5 [HP] , FCTS 40-200/30 : 3 [kW] - 4 [HP]

fcte-fcts-2p50S_c_th

** FCTE 50-250/92 : 9.2 [kW] - 12.5 [HP] , FCTS 50-250/110A : 11 [kW] - 15 [HP]

FCTE 65-200/92 : 9.2 [kW] - 12.5 [HP] , FCTS 65-200/110A : 11 [kW] - 15 [HP]

Performance according to ISO standards 9906 - Annex A.

FCTE-FCTS SERIES (PARALLEL OPERATION)

Hydraulic performance table at 50 Hz, 2 poles

PUMP TYPE	RATED POWER		Q = DELIVERY																		
	2 x kW	2 x HP	l/min 0	200	400	600	700	800	1000	1200	1600	1800	2000	2200	2400	2800	3200	3500	4250	5550	
			m ³ /h 0	12	24	36	42	48	60	72	96	108	120	132	144	168	192	210	255	333	
H = TOTAL HEAD IN COLUMN OF WATER (METRES)																					
40-125/07	0,75	1	17,9	15,9	11,7	5,6															
40-125/11	1,1	1,5	23,0	20,5	16,2	10,0	6,3														
40-160/15	1,5	2	28,4	26,0	21,6	15,4	11,7														
40-160/22	2,2	3	35,3	33,3	28,9	22,3	18,4														
40-200/ *	*	*	43,4	39,2	33,3	25,6															
40-200/40	4	5,5	52,5	48,5	42,8	35,3															
40-200/55	5,5	7,5	61,2	57,5	51,5	43,6	39,0														
40-250/75	7,5	10	75,1	69,5	62,8	54,6	49,9														
40-250/110	11	15	86,8	83,0	76,8	68,5	63,6														
50-125/11	1,1	1,5	14,2		12,7	10,6	9,3	7,8	4,4												
50-125/15	1,5	2	18,4		17,1	15,0	13,6	12,1	8,6	4,6											
50-160/22	2,2	3	26,4		24,0	21,6	20,1	18,5	14,8	10,4											
50-160/30	3	4	33,3		30,1	27,5	26,0	24,3	20,4	15,8											
50-160/40	4	5,5	39,5		36,8	34,1	32,5	30,7	26,5	21,6											
50-200/55	5,5	7,5	47,6		44,2	41,4	39,6	37,7	33,2												
50-200/75	7,5	10	56,9		53,3	50,4	48,6	46,6	42,0	36,4											
50-250/**	**	**	64,6		61,0	58,3	56,7	54,8	50,6	45,6											
50-250/110	11	15	75,1		71,2	68,4	66,7	64,9	60,8	55,9											
50-250/150	15	20	87,3		83,5	80,7	79,0	77,2	73,0	68,1	55,9										
65-125/22	2,2	3	18,1					15,8	14,5	12,8	8,3	5,4									
65-125/30	3	4	22,1					19,8	18,4	16,8	12,4	9,6									
65-125/40	4	5,5	25,7					24,2	23,0	21,5	17,4	14,7	11,7								
65-160/55	5,5	7,5	34,0					32,4	31,1	29,4	25,1	22,4	19,4								
65-160/75	7,5	10	41,8					39,4	37,9	36,1	31,6	28,8	25,7	22,3							
65-200/**	**	**	52,0					48,5	46,9	44,9	39,7	36,3	32,5	28,0							
65-200/110	11	15	58,7					54,2	52,5	50,4	45,1	41,7	37,7	33,2	27,9						
65-250/150	15	20	69,6					65,7	64,2	62,4	57,8	54,9	51,7	48,0	43,8						
65-250/185	18,5	25	78,3					74,1	72,5	70,7	66,0	63,2	60,0	56,4	52,4	43,0					
65-250/220	22	30	87,3					83,8	82,1	80,2	75,3	72,4	69,2	65,7	61,8	53,2					
80-125/30	3	4	15,7							14,1	12,4	11,3	10,2	9,0	7,8						
80-125/40	4	5,5	18,9							17,7	16,2	15,2	14,2	13,1	11,9						
80-125/55	5,5	7,5	23,6							21,7	20,4	19,6	18,8	17,8	16,7	14,2					
80-160/75	7,5	10	28,4							26,8	25,7	25,0	24,3	23,4	22,4	20,2					
80-200/110	11	15	40,9							38,2	36,5	35,5	34,3	33,1	31,8	28,7	25,1	22,1			
80-200/150	15	20	50,4							47,4	45,7	44,7	43,6	42,4	41,1	38,0	34,5	31,5			
80-200/185	18,5	25	57,8							54,5	52,8	51,8	50,7	49,5	48,2	45,3	41,9	39,0			
80-200/220	22	30	63,6							61,3	59,7	58,7	57,6	56,4	55,1	52,1	48,7	45,8			
100-160/110	11	15	28,8									27,7	27,3	26,8	26,3	25,0	23,5	22,3	18,5		
100-200/185	18,5	25	39,7											37,8	37,4	36,4	35,2	34,1	31,0	23,4	
100-200/220	22	30	47,5												45,3	44,9	43,9	42,8	41,8	38,7	30,9

* FCTE 40-200/40A : 4 [kW] - 5.5 [HP] , FCTS 40-200/30 : 3 [kW] - 4 [HP]

fcte-fcts-2p50P_c_th

** FCTE 50-250/92 : 9.2 [kW] - 12.5 [HP] , FCTS 50-250/110A : 11 [kW] - 15 [HP]

FCTE 65-200/92 : 9.2 [kW] - 12.5 [HP] , FCTS 65-200/110A : 11 [kW] - 15 [HP]

Performance according to ISO standards 9906 - Annex A.

FCTE4-FCTS4 SERIES (SINGLE OPERATION)

Hydraulic performance table at 50 Hz, 4 poles

2

PUMP TYPE	RATED POWER		Q = DELIVERY																				
			l/min	50	100	150	175	200	300	400	500	600	700	900	1200	1400	1600	1750	2000	2500			
	kW	HP	m ³ /h	0	3	6	9	10,5	12	18	24	30	36	42	54	72	84	96	105	120	150		
H = TOTAL HEAD METRES COLUMN OF WATER																							
40-125/02A *	0,25	0,33	4,6	4,2	3,3	2,1																	
40-125/02 *	0,25	0,33	5,7	5,2	4,3	3,0	2,2																
40-160/02 *	0,25	0,33	7,0	6,4	5,5	4,2	3,4	2,6															
40-160/03 *	0,37	0,5	8,8	8,3	7,3	6,0	5,2	4,3															
40-200/05	0,55	0,75	12,8	11,8	10,5	8,7	7,7																
40-200/07	0,75	1	14,5	13,6	12,2	10,3	9,3	8,1															
40-250/11	1,1	1,5	18,5	17,6	16,2	14,4	13,3	12,2															
40-250/15	1,5	2	20,9	20,0	18,6	16,7	15,6	14,4															
50-125/02 *	0,25	0,33	6,3		5,7	5,2	4,9	4,6	3,0														
50-125/03 *	0,37	0,5	7,9		7,3	6,8	6,4	6,0	4,3	2,4													
50-160/05 *	0,55	0,75	9,4		8,8	8,2	7,9	7,5	5,8	3,6													
50-200/07	0,75	1	11,7		10,7	10,0	9,6	9,2	7,1	4,2													
50-200/11	1,1	1,5	14,1		13,2	12,5	12,2	11,8	9,6	6,7													
50-250/15	1,5	2	18,1		17,0	16,3	16,0	15,6	13,7	11,3	8,1												
50-250/22	2,2	3	21,3		20,3	19,7	19,3	18,9	17,0	14,6	11,5												
65-125/03 *	0,37	0,5	5,6					4,9	4,3	3,4	2,3												
65-125/05 *	0,55	0,75	6,4					6,0	5,4	4,5	3,5												
65-160/07	0,75	1	8,4					8,0	7,3	6,3	5,2	3,8	2,3										
65-160/11	1,1	1,5	10,3					9,7	9,1	8,2	7,0	5,6	3,9										
65-200/15	1,5	2	14,3					13,2	12,3	11,2	9,7	7,6	4,8										
65-250/22	2,2	3	19,0					17,6	16,7	15,7	14,4	12,8	10,7	4,9									
65-250/30	3	4	21,4					20,1	19,3	18,3	17,1	15,5	13,6	8,5									
80-125/07	0,75	1	5,6						5,3	5,0	4,7	4,2	3,7	2,4									
80-125/11	1,1	1,5	7,0						6,6	6,3	6,0	5,7	5,2	4,0									
80-200/15	1,5	2	11,7						10,2	9,7	9,1	8,5	7,8	6,1									
80-200/22	2,2	3	14,7						13,3	12,8	12,2	11,5	10,8	9,2	6,3								
80-200/30	3	4	16,7						15,1	14,6	14,0	13,4	12,8	11,3	8,2								
80-250/40	4	5,5	19,6						19,1	18,6	18,1	17,4	16,7	14,8	11,2	8,2							
80-250/55	5,5	7,5	23,3						22,7	22,3	21,8	21,2	20,5	18,9	15,6	12,9							
100-160/15	1,5	2	7,9							7,6	7,4	7,1	6,4	5,0	4,0	2,9	2,1						
100-200/22	2,2	3	9,7								9,1	8,9	8,2	7,0	6,0	4,9	4,0	2,3					
100-200/30	3	4	11,6									10,9	10,7	10,0	8,8	7,8	6,6	5,6	3,8				
100-250/40	4	5,5	15,2										14,4	14,2	13,6	12,3	11,3	10,1	9,1	7,2			
100-250/55	5,5	7,5	18,7											17,8	17,6	17,0	15,7	14,8	13,6	12,7	10,9	6,7	
100-250/75	7,5	10	21,6												21,2	20,9	20,4	19,2	18,2	17,1	16,1	14,4	10,0

* FCTE4 VERSION ONLY

fcte4-fcts4-4p50S-en_th

Performances according to ISO 9906 - Annex A.

FCTE4-FCTS4 SERIES (PARALLEL OPERATION)

Hydraulic performance table at 50 Hz, 4 poles

PUMP TYPE	RATED POWER		Q = DELIVERY																		
	2 x kW	2 x HP	l/min	100	200	300	350	400	600	700	900	1000	1100	1600	1800	2400	3000	3500	4000	4600	
			m ³ /h	6	12	18	21	24	36	42	54	60	66	96	108	144	180	210	240	276	
H = TOTAL HEAD IN COLUMN OF WATER (METRES)																					
40-125/02A *	0,25	0,33	4,6	4,1	3,2	1,7															
40-125/02 *	0,25	0,33	5,8	5,2	4,2	2,6															
40-160/02 *	0,25	0,33	7,0	6,4	5,4	3,8	2,9														
40-160/03 *	0,37	0,5	8,8	8,3	7,2	5,6	4,6	3,5													
40-200/05	0,55	0,75	12,9	11,8	10,3	8,4															
40-200/07	0,75	1	14,8	13,6	12,1	10,2	9,0														
40-250/11	1,1	1,5	18,5	17,6	16,1	14,0	12,8														
40-250/15	1,5	2	21,1	20,0	18,5	16,4	15,2	13,9													
50-125/02 *	0,25	0,33	6,3		5,6	5,0	4,6	4,2	2,2												
50-125/03 *	0,37	0,5	8,1		7,2	6,5	6,1	5,7	3,6	2,3											
50-160/05 *	0,55	0,75	9,6		8,8	8,1	7,7	7,2	5,0	3,6											
50-200/07	0,75	1	11,5		10,6	9,8	9,3	8,8	6,3	4,7											
50-200/11	1,1	1,5	14,0		13,0	12,3	11,8	11,3	8,7	7,1											
50-250/15	1,5	2	18,1		17,0	16,2	15,7	15,3	12,9	11,5	7,9										
50-250/22	2,2	3	21,3		20,2	19,4	19,0	18,5	16,0	14,6	11,0										
65-125/03 *	0,37	0,5	5,5					4,7	4,0	3,5	2,2										
65-125/05 *	0,55	0,75	6,3					5,9	5,2	4,7	3,4	2,7									
65-160/07	0,75	1	8,5					7,8	7,0	6,5	5,3	4,5	3,7								
65-160/11	1,1	1,5	10,2					9,7	8,9	8,3	7,0	6,2	5,4								
65-200/15	1,5	2	14,4					13,1	12,1	11,4	9,8	8,8	7,6								
65-250/22	2,2	3	19,3					17,7	16,6	16,1	14,6	13,8	12,8	5,9							
65-250/30	3	4	21,6					20,2	19,3	18,7	17,3	16,5	15,5	9,2							
80-125/07	0,75	1	5,7						5,2	5,0	4,6	4,4	4,1	2,4							
80-125/11	1,1	1,5	7,0						6,6	6,4	6,1	5,9	5,6	4,1	3,3						
80-200/15	1,5	2	11,5						10,1	9,8	9,2	8,9	8,6	6,5	5,5						
80-200/22	2,2	3	14,8						13,2	12,9	12,3	12,0	11,7	9,7	8,7						
80-200/30	3	4	16,7						15,7	15,4	14,9	14,6	14,2	12,0	10,9	6,8					
80-250/40	4	5,5	19,8						19,1	18,8	18,3	17,9	17,6	15,3	14,1	9,9					
80-250/55	5,5	7,5	23,2						22,6	22,4	21,9	21,6	21,3	19,2	18,2	14,3					
100-160/15	1,5	2	7,8							7,5	7,4	7,3	6,5	6,1	4,5	2,5					
100-200/22	2,2	3	9,7										9,1	8,3	7,9	6,4	4,5	2,6			
100-200/30	3	4	11,6										11,0	10,2	9,8	8,3	6,4	4,5	2,1		
100-250/40	4	5,5	15,1										14,4	13,7	13,3	11,8	9,9	7,9	5,5		
100-250/55	5,5	7,5	18,7										17,8	17,1	16,7	15,5	13,7	11,8	9,5	6,0	
100-250/75	7,5	10	21,6										21,1	20,4	20,1	18,8	17,1	15,3	13,1	9,9	

* ONLY FCTE4 VERSION

fcte4-fcts4-4p50P_e_th

Performance according to ISO standards 9906 - Annex A.

FCTS4 SERIES (SINGLE OPERATION)

Hydraulic performance table at 50 Hz, 4 poles

2

PUMP TYPE	RATED POWER		Q = DELIVERY																	
			l/min 0	900	1100	1333	1583	1667	1833	1917	2000	2333	2500	3000	3167	3667	4083	4500	4733	5167
			m ³ /h 0	54	66	80	95	100	110	115	120	140	150	180	190	220	245	270	284	310
kW		HP	H = TOTAL HEAD METRES COLUMN OF WATER																	
125-160/30	3	4	10,1	8,7	8,2	7,5	6,6	6,3	5,7	5,3	5,0	3,4								
125-200/40	4	5,5	12,4	10,9	10,4	9,6	8,6	8,3	7,5	7,1	6,7	5,0	4,0							
125-200/55	5,5	7,5	15,0	13,6	13,1	12,3	11,4	11,1	10,3	10,0	9,6	7,8	6,8							
125-250/75	7,5	10	19,9	18,5	17,9	17,0	15,8	15,4	14,5	14,0	13,4	11,1	9,7							
125-250/110	11	15	25,5	24,0	23,5	22,7	21,7	21,3	20,5	20,0	19,5	17,3	16,0	11,3	9,5					
150-200/55	5,5	7,5	11,8			9,6	9,1	9,0	8,6	8,5	8,3	7,5	7,1	5,7	5,2	3,5				
150-200/75	7,5	10	15,4			13,3	12,9	12,8	12,5	12,3	12,1	11,4	11,0	9,5	9,0	7,0	5,0			
150-250/110	11	15	18,0			17,0	16,7	16,6	16,3	16,1	16,0	15,2	14,8	13,1	12,5	10,2				
150-250/150	15	20	22,1			21,3	21,0	20,8	20,5	20,4	20,2	19,4	19,0	17,5	17,0	15,0	13,2	11,1	9,8	
150-250/185	18,5	25	25,1			24,1	23,8	23,7	23,5	23,3	23,2	22,6	22,3	21,1	20,6	18,9	17,1	15,0	13,7	10,9

Performances according to ISO 9906 - Annex A

lmz-fcts4-4p50S-en_b_th

PUMP TYPE	RATED POWER		Q = DELIVERY																	
			l/min 0	1800	2200	2667	3000	3250	3500	3750	4000	4333	4833	5200	5667	6500	7333	7667	8333	9000
			m ³ /h 0	108	132	160	180	195	210	225	240	260	290	312	340	390	440	460	500	540
kW		HP	H = TOTAL HEAD METRES COLUMN OF WATER																	
125-160/30	3	4	10,2	8,8	8,1	7,2	6,5	5,9	5,3	4,7	4,1	3,2								
125-200/40	4	5,5	12,7	11,2	10,6	9,7	9,0	8,4	7,8	7,1	6,3	5,2								
125-200/55	5,5	7,5	15,1	14,4	14,0	13,3	12,7	12,2	11,6	10,9	10,1	9,0	7,0							
125-250/75	7,5	10	20,3	17,8	17,2	16,4	15,6	15,0	14,2	13,4	12,4	10,9	8,2							
125-250/110	11	15	25,6	24,4	23,7	22,6	21,7	21,0	20,2	19,3	18,4	17,1	14,9	13,2	10,8					
150-200/55	5,5	7,5	11,6				8,6	8,2	7,9	7,5	7,1	6,6	5,8	5,2	4,5					
150-200/75	7,5	10	15,4				12,7	12,4	12,0	11,6	11,2	10,7	9,9	9,2	8,3	6,7				
150-250/110	11	15	18,7				17,2	16,9	16,6	16,3	16,0	15,5	14,7	14,0	13,1	11,2	9,0	8,0		
150-250/150	15	20	22,7				21,5	21,3	21,0	20,7	20,4	20,0	19,2	18,6	17,7	15,9	13,8	12,9	10,9	
150-250/185	18,5	25	25,4				24,5	24,3	24,0	23,7	23,4	23,0	22,2	21,6	20,8	19,1	17,2	16,4	14,7	12,9

Performances according to ISO 9906 - Annex A

lmz-fcts4-4p50P-en_c_th

FCTE-FCTS SERIES

Operating characteristics at 50 Hz, 2 poles

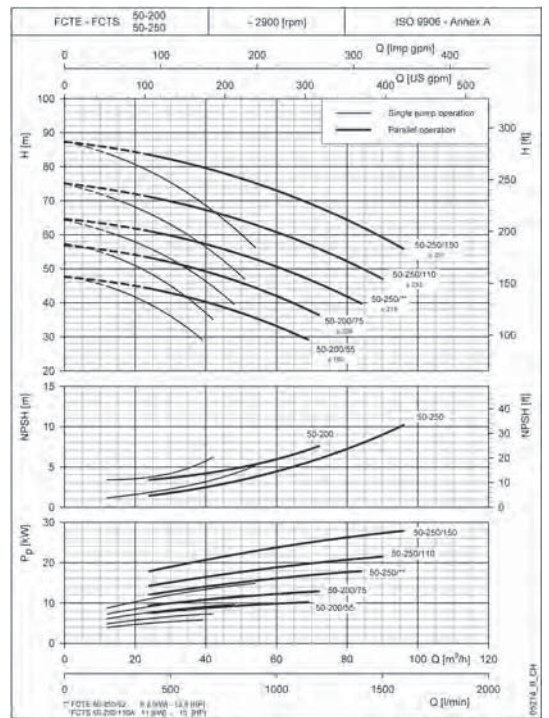
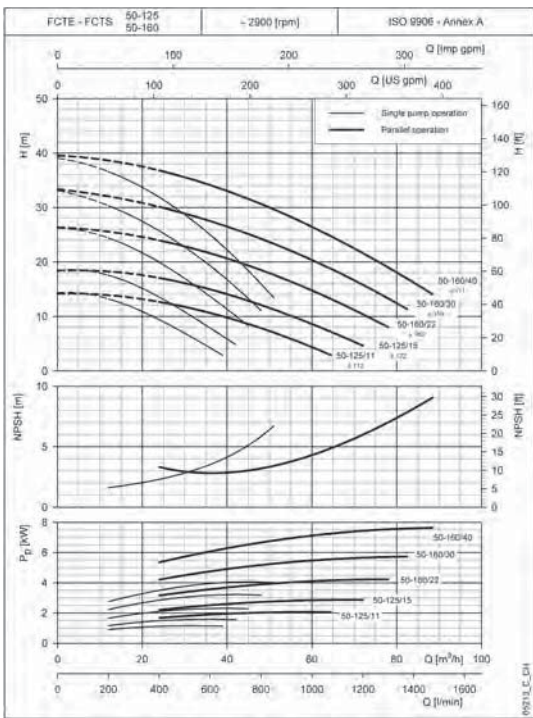
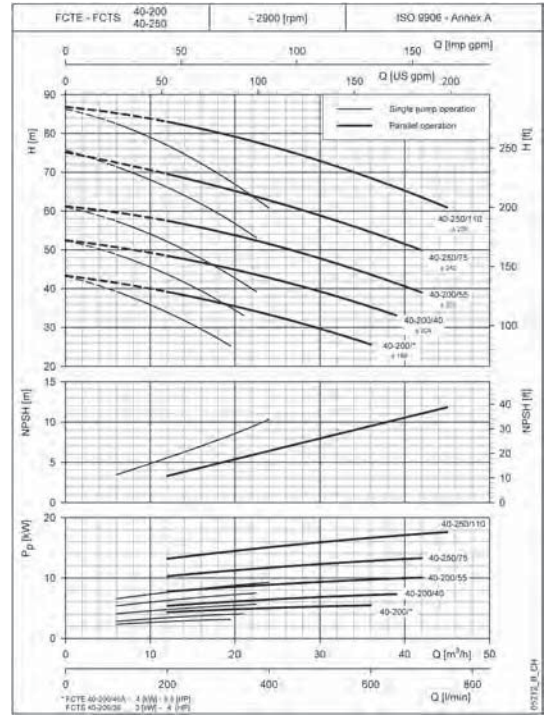
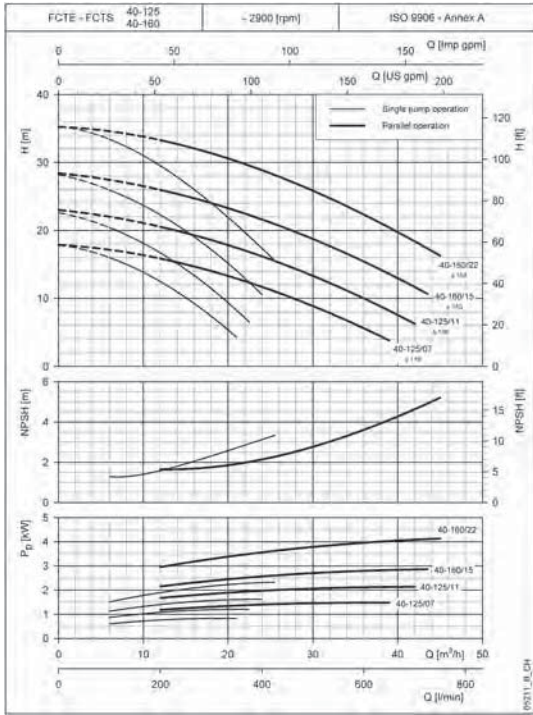

These NPSH values are valid in laboratory conditions; for practical purposes, values should be increased by a 0.5 m safety margin.

These performances are valid for liquids with density $\rho = 1.0 \text{ kg/dm}^3$ and kinematic viscosity $\nu = 1 \text{ mm}^2/\text{s}$.

FCTE-FCTS SERIES

Operating characteristics at 50 Hz, 2 poles

2

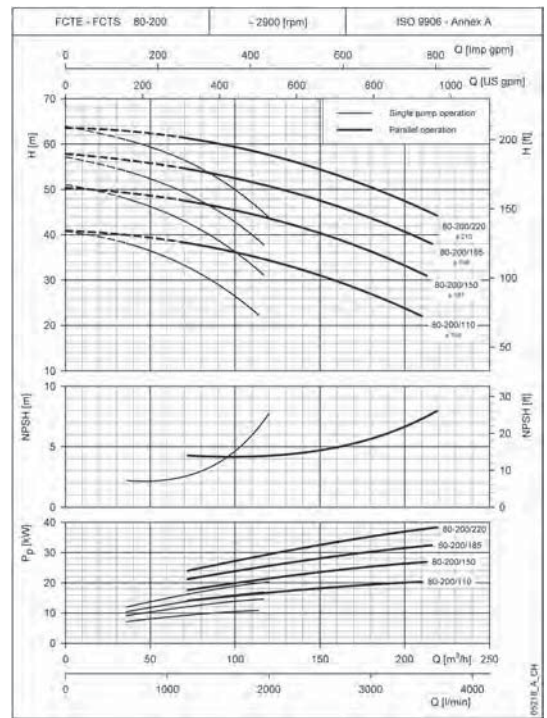
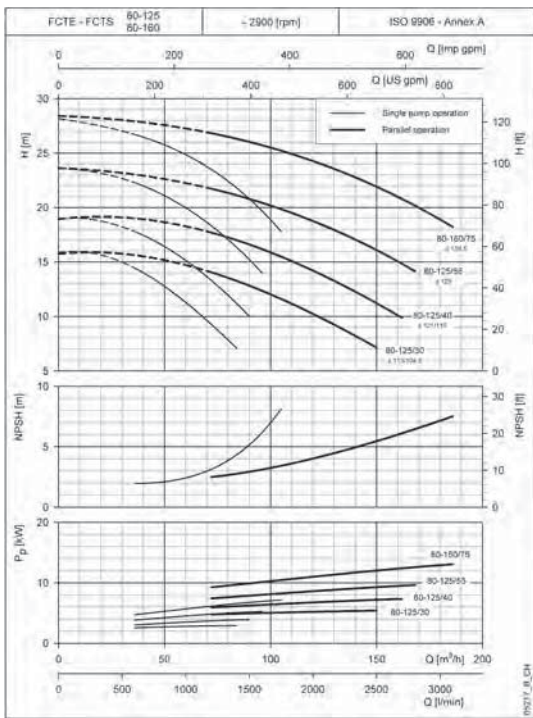
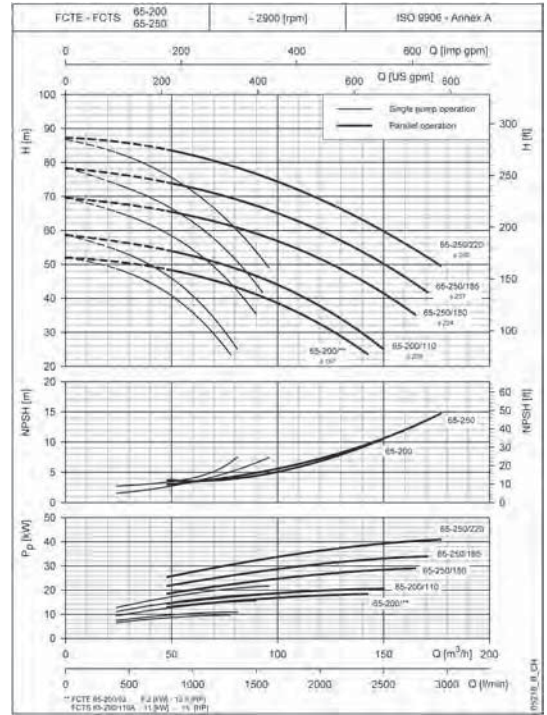
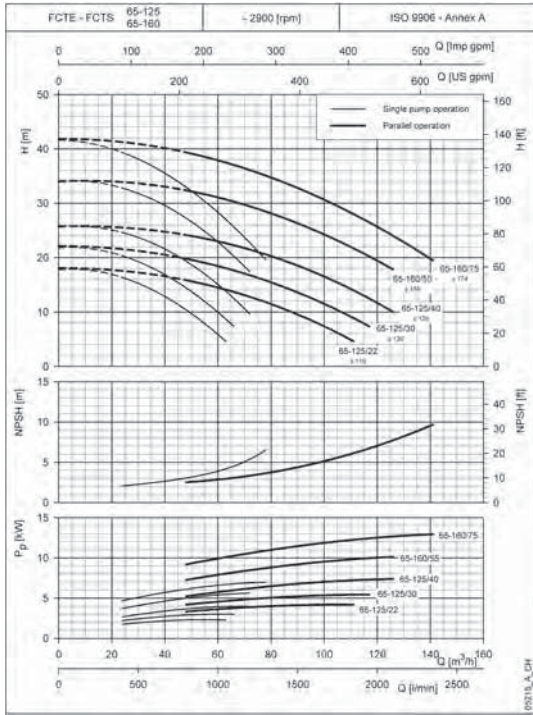

These NPSH values are valid in laboratory conditions; for practical purposes, values should be increased by a 0.5 m safety margin.

These performances are valid for liquids with density $\rho = 1.0 \text{ kg/dm}^3$ and kinematic viscosity $\nu = 1 \text{ mm}^2/\text{s}$.

FCTE-FCTS SERIES

Operating characteristics at 50 Hz, 2 poles

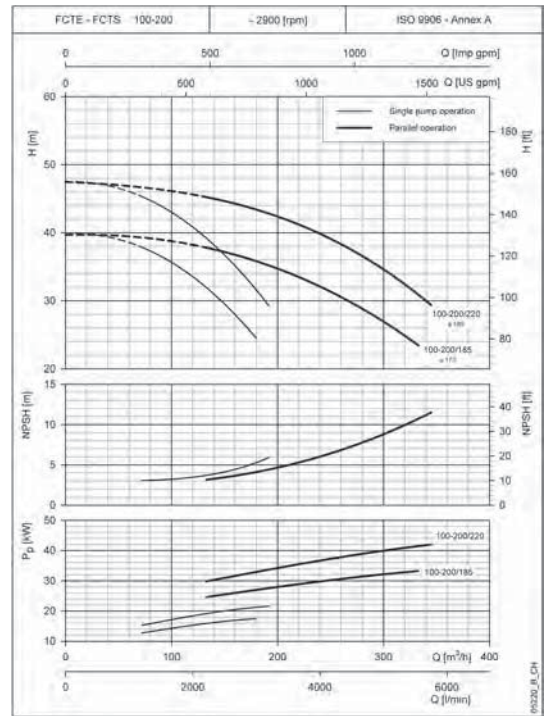
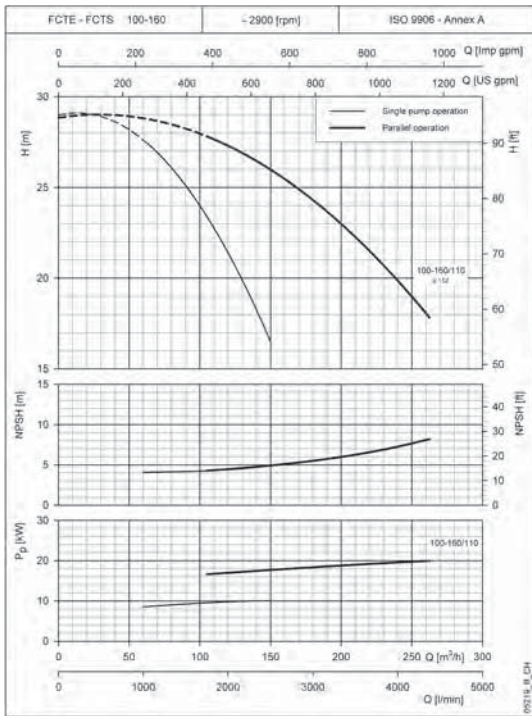

2

These NPSH values are valid in laboratory conditions; for practical purposes, values should be increased by a 0.5 m safety margin.

These performances are valid for liquids with density $\rho = 1.0 \text{ kg/dm}^3$ and kinematic viscosity $\nu = 1 \text{ mm}^2/\text{s}$.

Black and white technical books available
see www.lowara.it

FCTE4-FCTS4 SERIES

Operating characteristics at 50 Hz, 4 poles

2

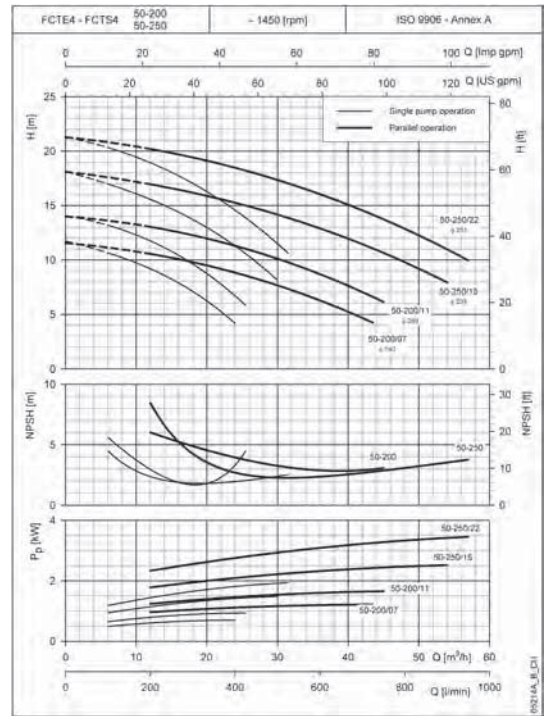
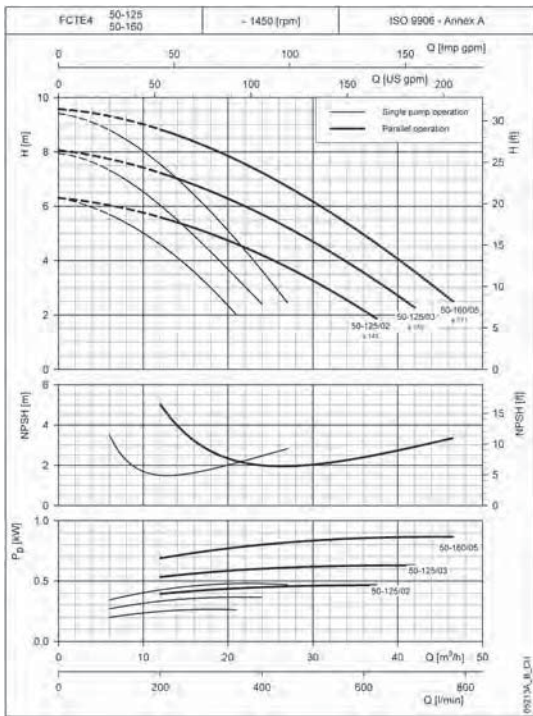
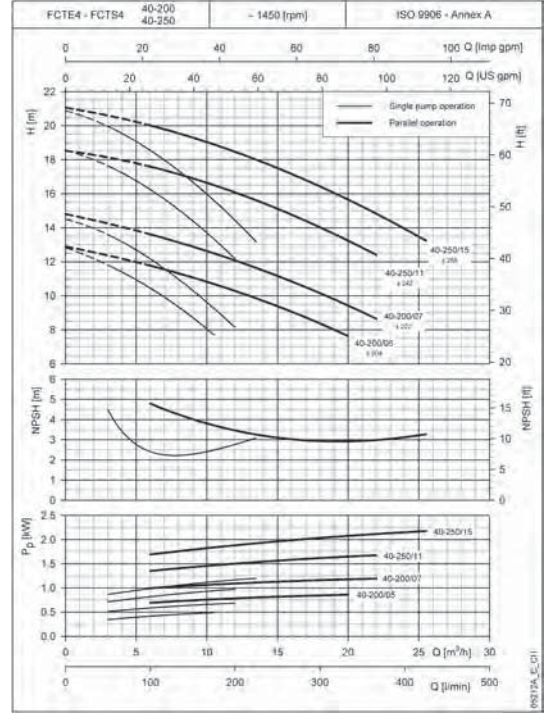
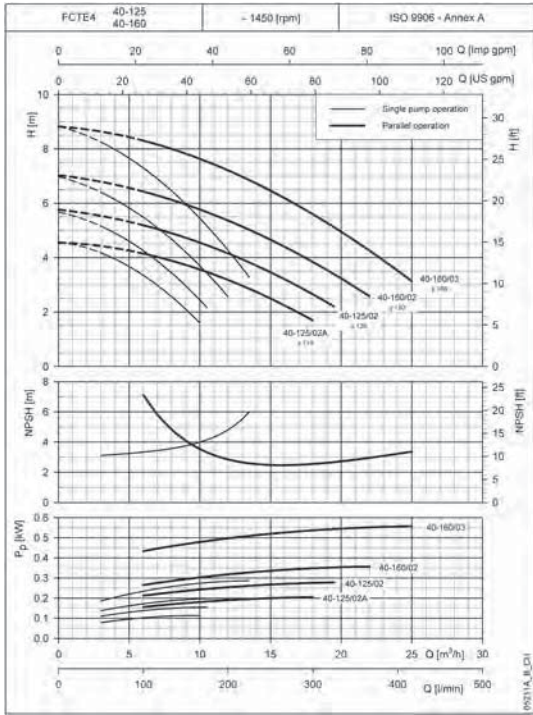

These NPSH values are valid in laboratory conditions; for practical purposes, values should be increased by a 0.5 m safety margin.

These performances are valid for liquids with density $\rho = 1.0 \text{ kg/dm}^3$ and kinematic viscosity $\nu = 1 \text{ mm}^2/\text{s}$.

FCTE4-FCTS4 SERIES

Operating characteristics at 50 Hz, 4 poles

2

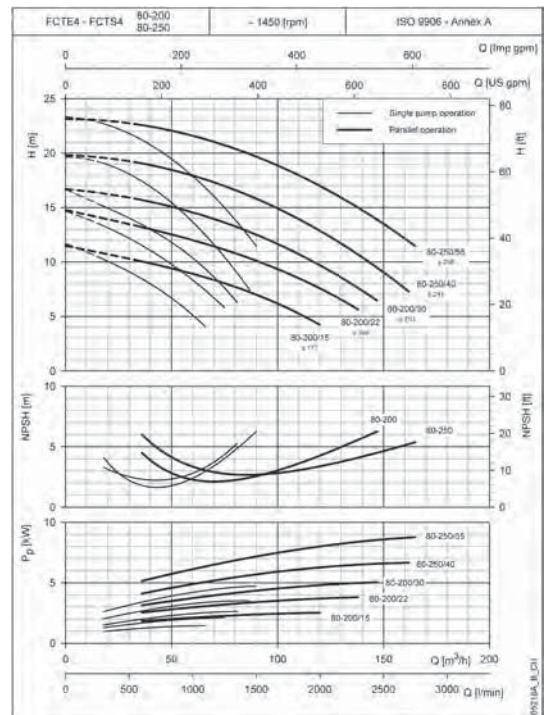
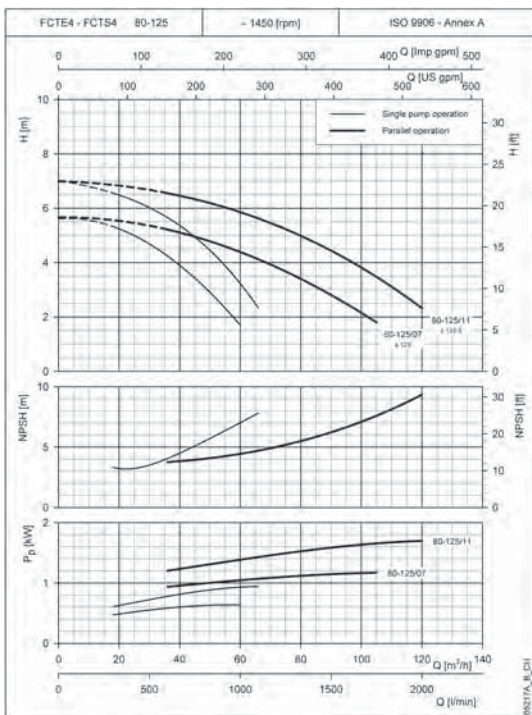
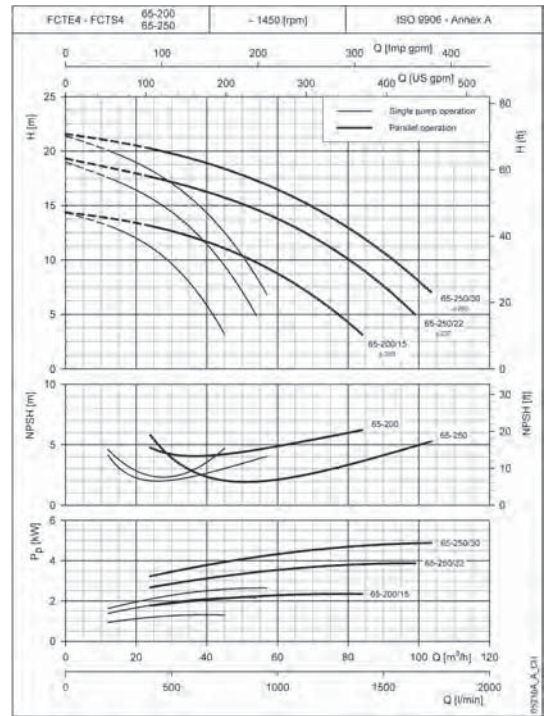
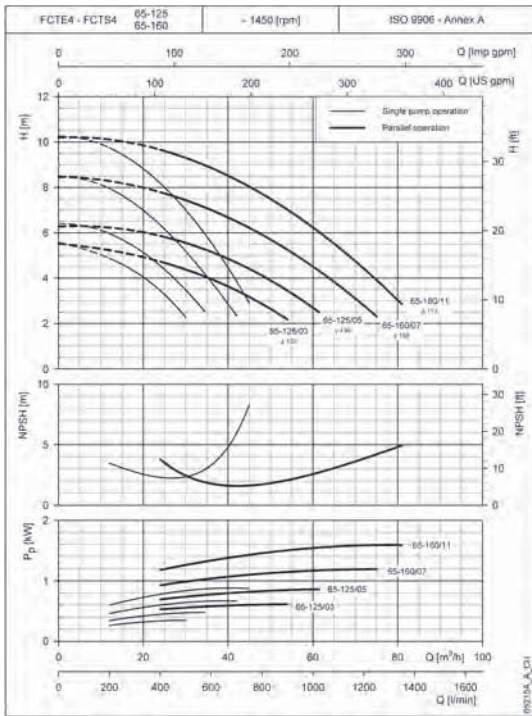

These NPSH values are valid in laboratory conditions; for practical purposes, values should be increased by a 0.5 m safety margin.

These performances are valid for liquids with density $\rho = 1.0 \text{ kg/dm}^3$ and kinematic viscosity $\nu = 1 \text{ mm}^2/\text{s}$.

FCTE4-FCTS4 SERIES

Operating characteristics at 50 Hz, 4 poles

2

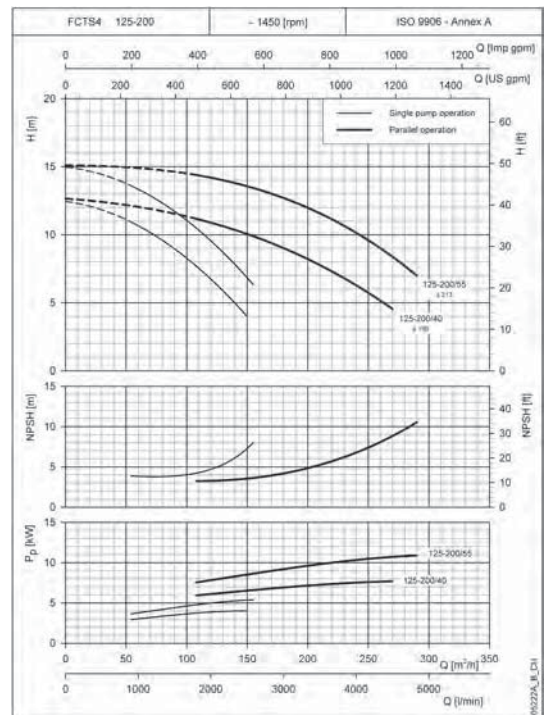
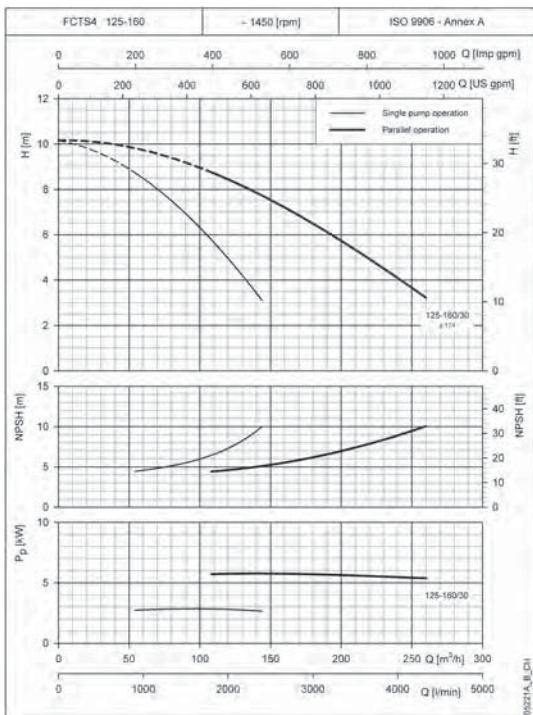
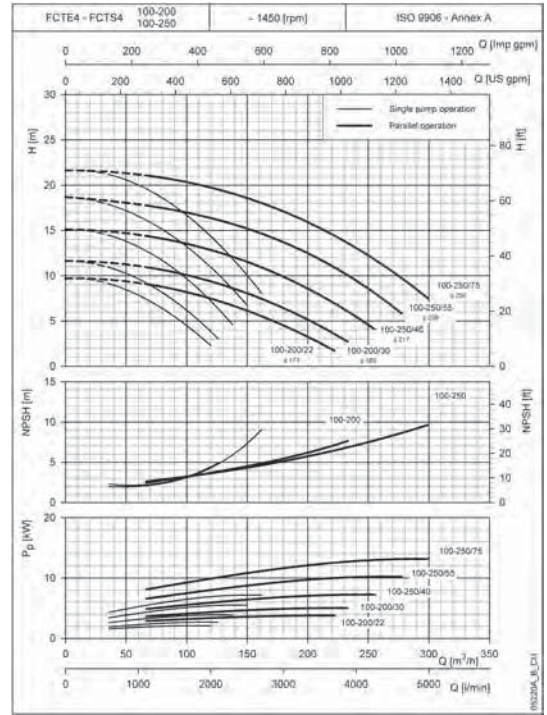
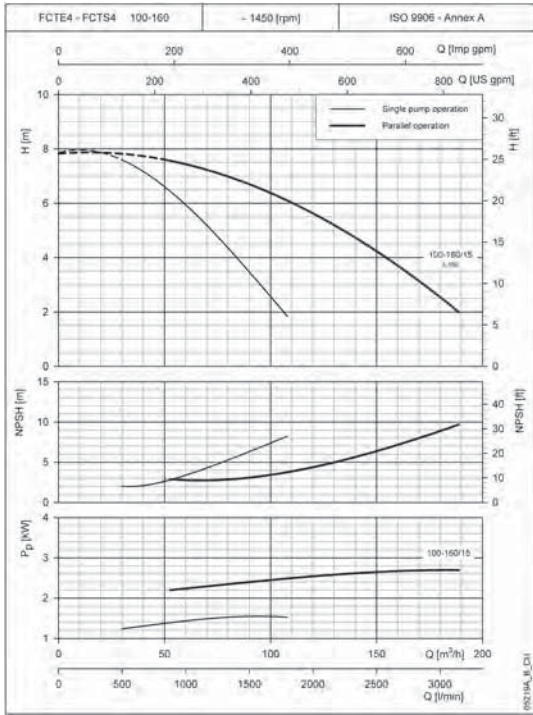

These NPSH values are valid in laboratory conditions; for practical purposes, values should be increased by a 0.5 m safety margin.

These performances are valid for liquids with density $\rho = 1.0 \text{ kg/dm}^3$ and kinematic viscosity $\nu = 1 \text{ mm}^2/\text{s}$.

FCTS4 SERIES

Operating characteristics at 50 Hz, 4 poles

2

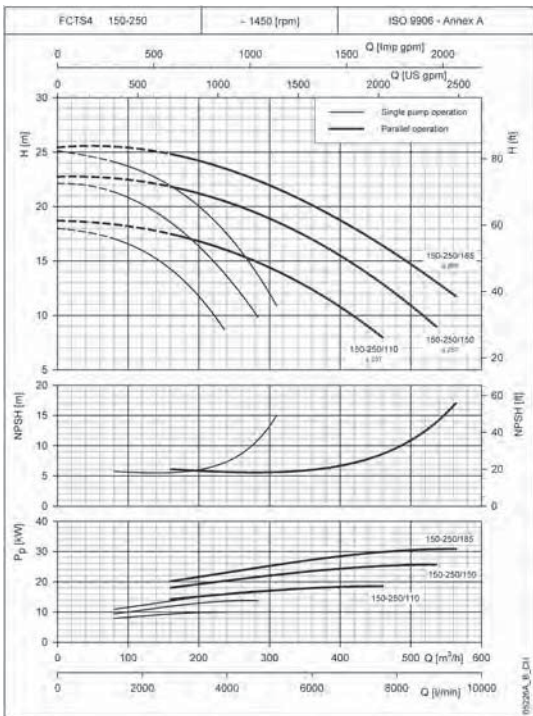
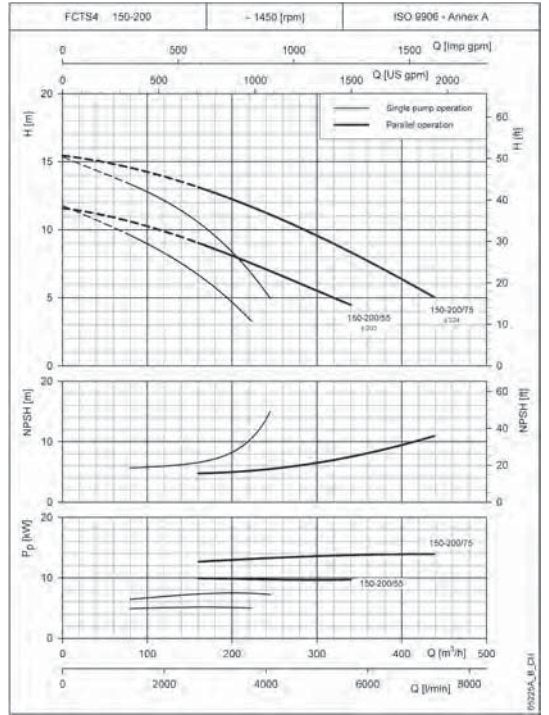
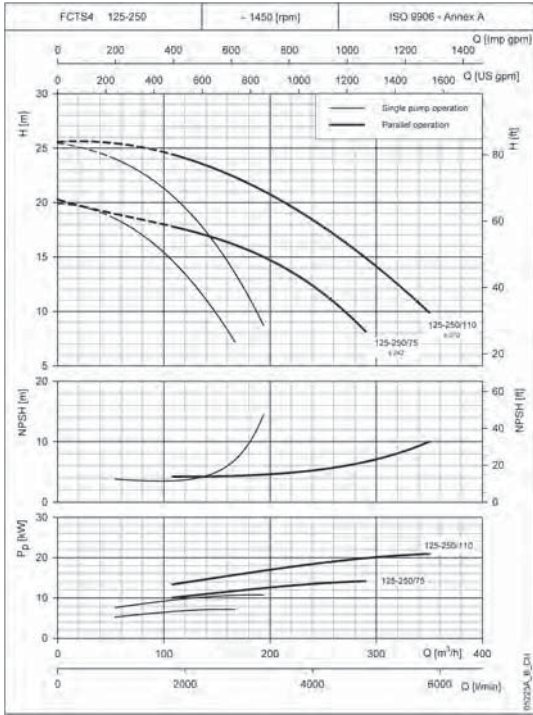

These NPSH values are valid in laboratory conditions; for practical purposes, values should be increased by a 0.5 m safety margin.

These performances are valid for liquids with density $\rho = 1.0 \text{ kg/dm}^3$ and kinematic viscosity $\nu = 1 \text{ mm}^2/\text{s}$.

FCE SERIES

Dimensions and weights at 50 Hz

2

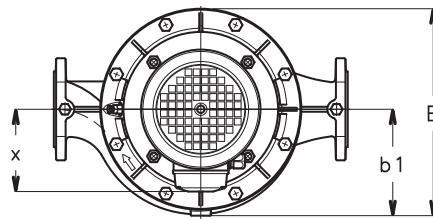
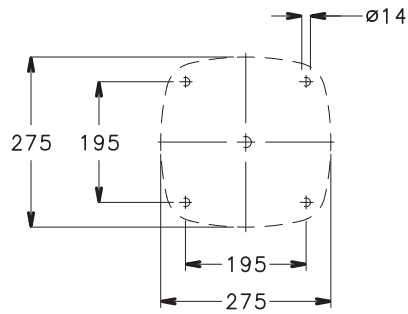
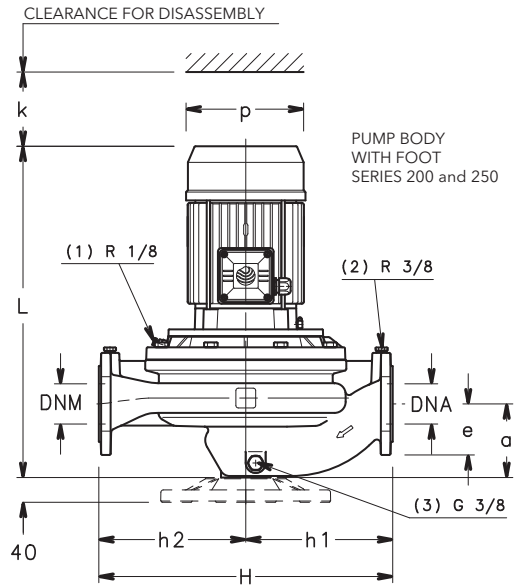
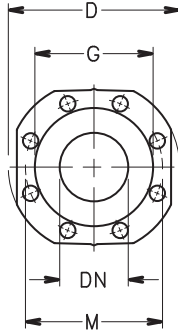
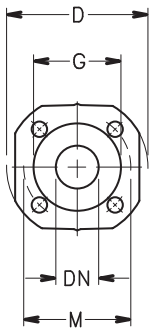
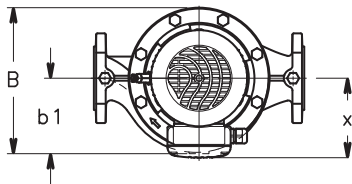
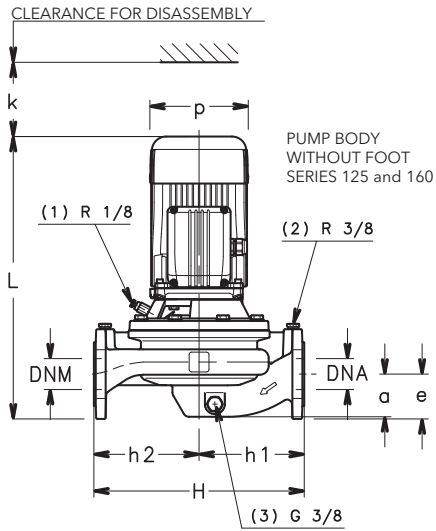

PUMP FLANGES

DN	D	M	G	HOLES		THICKNESS MAX.
				Nº	DIA.	
40	150	110	88	4	18	18
50	165	125	102	4	18	20
65	185	145	122	4	18	20
80	200	160	138	8	18	22
100	220	180	158	8	18	22

- (1) R 1/8 AIR VALVE
- (2) R 3/8 PRESSURE GAUGE CONNECTOR
- (3) G 3/8 GAUGE

04804D_B_DD

FCE SERIES

Dimensions and weights at 50 Hz

PUMP TYPE	DIMENSIONS (mm)													WEIGHT
	DNA	DNM	a	e	h1	h2	x	b1	p	B	H max	L	k	kg
FCE 40-125/07	40	40	70	70	160	160	129	116	155	243	320	448	86	30
FCE 40-125/11	40	40	70	70	160	160	129	116	155	243	320	448	86	31
FCE 40-160/15	40	40	70	70	160	160	134	116	174	248	320	483	86	34
FCE 40-160/22	40	40	70	70	160	160	134	116	174	248	320	483	86	35
FCE 40-200/40A	40	40	95	65	220	220	154	163	197	325	440	514	98	72
FCE 40-200/40	40	40	95	65	220	220	154	163	197	325	440	514	98	72
FCE 40-200/55	40	40	95	65	220	220	168	163	214	330	440	548	98	73
FCE 40-250/75	40	40	95	65	220	220	191	163	256	353	440	562	98	91
FCE 40-250/110	40	40	95	65	220	220	191	163	256	353	440	600	98	92
FCE 50-125/11	50	50	69	73	170	170	129	122	155	243	340	457	88	33
FCE 50-125/15	50	50	69	73	170	170	134	122	174	248	340	492	88	38
FCE 50-160/22	50	50	69	73	170	170	134	122	174	248	340	492	88	44
FCE 50-160/30	50	50	69	73	170	170	134	122	174	248	340	492	88	46
FCE 50-160/40	50	50	69	73	170	170	154	122	197	268	340	513	88	49
FCE 50-200/55	50	50	110	73	220	220	168	163	214	331	440	577	100	56
FCE 50-200/75	50	50	110	73	220	220	191	163	256	354	440	591	100	72
FCE 50-250/92	50	50	110	73	220	220	191	163	256	354	440	629	100	101
FCE 50-250/110	50	50	110	73	220	220	191	163	256	354	440	629	100	107
FCE 50-250/150	50	50	110	73	220	220	240	163	313	403	440	718	100	115
FCE 65-125/22	65	65	77	83	170	170	134	137	174	274	340	511	92	54
FCE 65-125/30	65	65	77	83	170	170	134	137	174	274	340	511	92	57
FCE 65-125/40	65	65	77	83	170	170	154	137	197	291	340	532	92	61
FCE 65-160/55	65	65	77	83	170	170	168	137	214	305	340	566	92	69
FCE 65-160/75	65	65	77	83	170	170	191	137	256	328	340	580	92	86
FCE 65-200/92	65	65	119	83	237,5	237,5	191	172	256	354	475	634	104	105
FCE 65-200/110	65	65	119	83	237,5	237,5	191	172	256	354	475	634	104	112
FCE 65-250/150	65	65	119	83	237,5	237,5	240	172	313	403	475	723	104	128
FCE 65-250/185	65	65	119	83	237,5	237,5	240	172	313	403	475	723	104	138
FCE 65-250/220	65	65	119	83	237,5	237,5	240	172	313	403	475	723	104	150
FCE 80-125/30	80	80	90	90	175	185	134	148	174	287	360	545	102	64
FCE 80-125/40	80	80	90	90	175	185	154	148	197	293	360	566	102	67
FCE 80-125/55	80	80	90	90	175	185	168	148	214	307	360	600	102	69
FCE 80-160/75	80	80	90	90	175	185	191	148	256	330	360	614	102	85
FCE 80-200/110	80	80	130	90	250	250	191	184	256	354	500	661	112	120
FCE 80-200/150	80	80	130	90	250	250	240	184	313	403	500	750	112	130
FCE 80-200/185	80	80	130	90	250	250	240	184	313	403	500	750	112	140
FCE 80-200/220	80	80	130	90	250	250	240	184	313	403	500	750	112	152
FCE 100-160/110	100	100	105	105	225	225	191	172	256	330	450	677	117	127
FCE 100-200/185	100	100	140	105	275	275	240	196	313	406	550	771	129	180
FCE 100-200/220	100	100	140	105	275	275	240	196	313	406	550	771	129	192

fc_fce-2p50-en_f_td

FCE4 SERIES

Dimensions and weights at 50 Hz

2

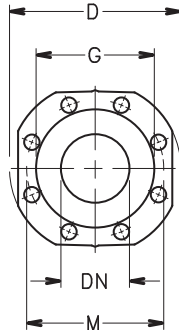
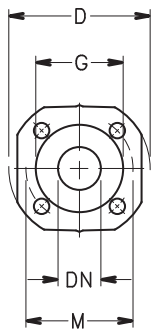
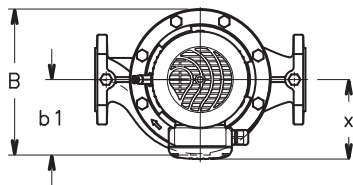
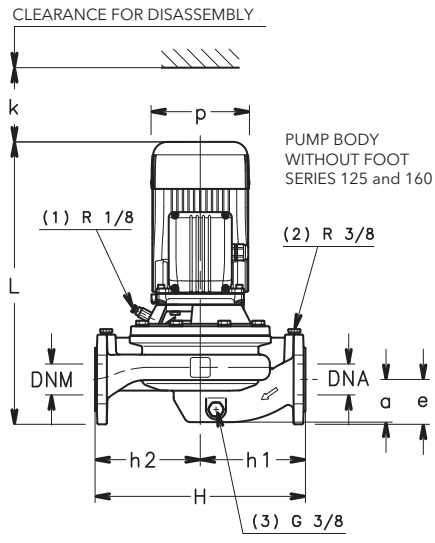

PUMP FLANGES

DN	D	M	G	HOLES		THICKNESS MAX.
				N°	DIA.	
40	150	110	88	4	18	18
50	165	125	102	4	18	20
65	185	145	122	4	18	20
80	200	160	138	8	18	22
100	220	180	158	8	18	22

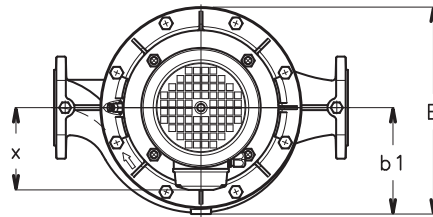
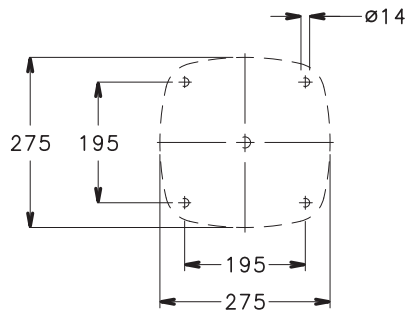
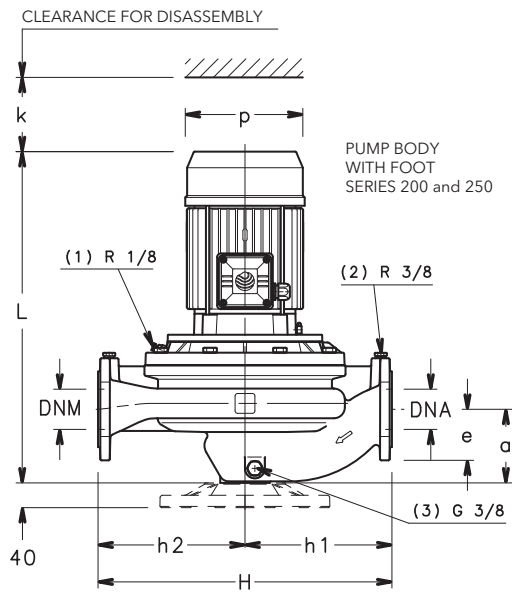

- (1) R 1/8 AIR VALVE
- (2) R 3/8 PRESSURE GAUGE CONNECTOR
- (3) G 3/8 GAUGE

04804D_B_DD

FCE4 SERIES

Dimensions and weights at 50 Hz

PUMP TYPE	DIMENSIONS (mm)										WEIGHT			
	DNA	DNM	a	e	h1	h2	x	b1	p	B	H max	L	k	kg
FCE4 40-125/02A	40	40	70	70	160	160	121	116	140	235	320	416	86	24
FCE4 40-125/02	40	40	70	70	160	160	121	116	140	235	320	416	86	24
FCE4 40-160/02	40	40	70	70	160	160	121	116	140	235	320	416	86	25
FCE4 40-160/03	40	40	70	70	160	160	121	116	140	235	320	416	86	26
FCE4 40-200/05	40	40	95	65	220	220	129	163	155	325	440	458	98	44
FCE4 40-200/07	40	40	95	65	220	220	128	163	159	325	440	426	98	45
FCE4 40-250/11	40	40	95	65	220	220	134	163	174	325	440	493	98	64
FCE4 40-250/15	40	40	95	65	220	220	134	163	174	325	440	493	98	65
FCE4 50-125/02	50	50	69	73	170	170	121	122	140	236	340	425	88	28
FCE4 50-125/03	50	50	69	73	170	170	121	122	140	236	340	425	88	29
FCE4 50-160/05	50	50	69	73	170	170	129	122	155	243	340	457	88	31
FCE4 50-200/07	50	50	110	73	220	220	128	163	159	326	440	455	100	54
FCE4 50-200/11	50	50	110	73	220	220	134	163	174	326	440	522	100	63
FCE4 50-250/15	50	50	110	73	220	220	134	163	174	326	440	522	100	66
FCE4 50-250/22	50	50	110	73	220	220	168	163	214	331	440	546	100	72
FCE4 65-125/03	65	65	77	83	170	170	121	137	140	274	340	444	92	38
FCE4 65-125/05	65	65	77	83	170	170	129	137	155	274	340	476	92	42
FCE4 65-160/07	65	65	77	83	170	170	128	137	159	274	340	444	92	47
FCE4 65-160/11	65	65	77	83	170	170	134	137	174	274	340	511	92	54
FCE4 65-200/15	65	65	119	83	237,5	237,5	134	172	174	335	475	527	104	69
FCE4 65-250/22	65	65	119	83	237,5	237,5	168	172	214	335	475	551	104	80
FCE4 65-250/30	65	65	119	83	237,5	237,5	168	172	214	335	475	582	104	82
FCE4 80-125/07	80	80	90	90	175	185	128	148	159	287	360	478	102	51
FCE4 80-125/11	80	80	90	90	175	185	134	148	174	287	360	545	102	59
FCE4 80-200/15	80	80	130	90	250	250	134	184	174	347	500	554	112	81
FCE4 80-200/22	80	80	130	90	250	250	168	184	214	347	500	578	112	87
FCE4 80-200/30	80	80	130	90	250	250	168	184	214	347	500	609	112	91
FCE4 80-250/40	80	80	130	90	250	250	168	184	214	347	500	654	112	117
FCE4 80-250/55	80	80	130	90	250	250	191	184	256	354	500	661	112	125
FCE4 100-160/15	100	100	105	105	225	225	134	172	174	311	450	570	117	74
FCE4 100-200/22	100	100	140	105	275	275	168	196	214	362	550	599	129	99
FCE4 100-200/30	100	100	140	105	225	275	168	196	214	362	550	630	129	101
FCE4 100-250/40	100	100	140	105	275	275	168	196	214	362	550	675	129	125
FCE4 100-250/55	100	100	140	105	275	275	191	196	256	362	550	682	129	131
FCE4 100-250/75	100	100	140	105	275	275	191	196	256	362	550	682	129	141

fc_fce4-4p50-en_f_td

FCS SERIES

Dimensions and weights at 50 Hz

2

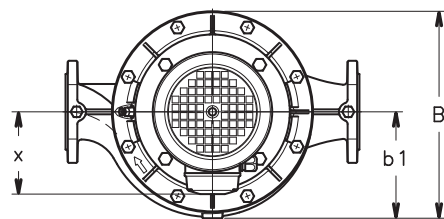
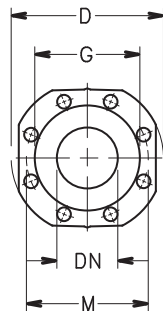
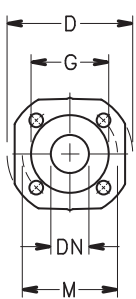
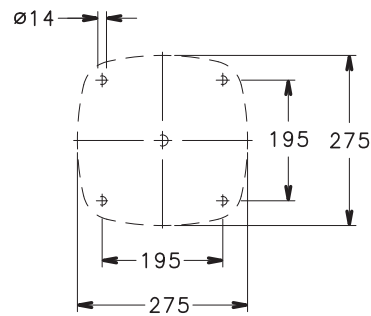
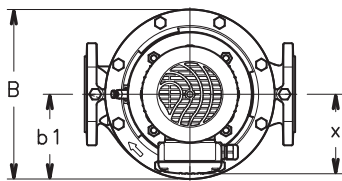
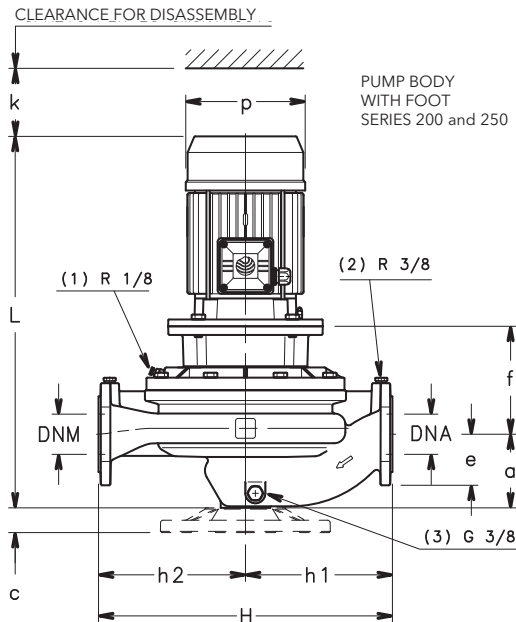
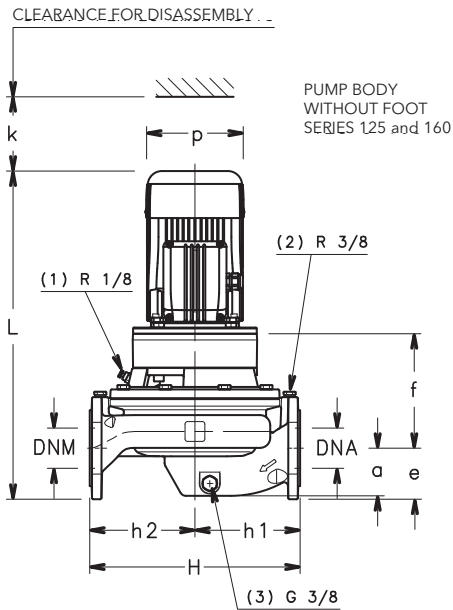

PUMP FLANGES

DN	D	M	G	HOLES		THICKNESS
				N°	DIA.	MAX.
40	150	110	88	4	18	18
50	165	125	102	4	18	20
65	185	145	122	4	18	20
80	200	160	138	8	18	22
100	220	180	158	8	18	22

- (1) R 1/8 AIR VALVE
- (2) R 3/8 PRESSURE GAUGE CONNECTOR
- (3) G 3/8 GAUGE

04854D_B_DD

FCS SERIES

Dimensions and weights at 50 Hz

PUMP TYPE	DIMENSIONS (mm)										WEIGHT				
	DNA	DNM	a	e	f	h1	h2	x	b1	p	B	H max	L	k	kg
FCS 40-125/07	40	40	70	70	170	160	160	129	116	155	243	320	503	86	33
FCS 40-125/11	40	40	70	70	170	160	160	129	116	155	243	320	503	86	34
FCS 40-160/15	40	40	70	70	170	160	160	134	116	174	248	320	538	86	37
FCS 40-160/22	40	40	70	70	170	160	160	134	116	174	248	320	538	86	39
FCS 40-200/30	40	40	95	65	165	220	220	134	163	174	325	440	558	98	69
FCS 40-200/40	40	40	95	65	165	220	220	154	163	197	325	440	579	98	75
FCS 40-200/55	40	40	95	65	192	220	220	168	163	214	330	440	662	98	88
FCS 40-250/75	40	40	95	65	192	220	220	191	163	256	353	440	654	98	106
FCS 40-250/110	40	40	95	65	222	220	220	191	163	256	353	440	745	98	120
FCS 50-125/11	50	50	69	73	176	170	170	129	122	155	243	340	512	88	38
FCS 50-125/15	50	50	69	73	176	170	170	134	122	174	248	340	547	88	42
FCS 50-160/22	50	50	69	73	176	170	170	134	122	174	248	340	547	88	50
FCS 50-160/30	50	50	69	73	186	170	170	134	122	174	248	340	557	88	51
FCS 50-160/40	50	50	69	73	186	170	170	154	122	197	268	340	578	88	58
FCS50-200/55	50	50	110	73	206	220	220	168	163	214	331	440	691	100	91
FCS 50-200/75	50	50	110	73	206	220	220	191	163	256	354	440	683	100	108
FCS 50-250/110A	50	50	110	73	236	220	220	191	163	256	354	440	774	100	115
FCS 50-250/110	50	50	110	73	236	220	220	191	163	256	354	440	774	100	115
FCS 50-250/150	50	50	110	73	236	220	220	240	163	313	403	440	840	100	125
FCS 65-125/22	65	65	77	83	185	170	170	134	137	174	274	340	566	92	69
FCS 65-125/30	65	65	77	83	195	170	170	134	137	174	274	340	576	92	62
FCS 65-125/40	65	65	77	83	195	170	170	154	137	197	291	340	597	92	67
FCS 65-160/55	65	65	77	83	222	170	170	168	137	214	305	340	680	92	80
FCS 65-160/75	65	65	77	83	222	170	170	191	137	256	328	340	672	92	95
FCS 65-200/110A	65	65	119	83	232	237,5	237,5	191	172	256	354	475	779	104	133
FCS 65-200/110	65	65	119	83	232	237,5	237,5	191	172	256	354	475	779	104	133
FCS 65-250/150	65	65	119	83	232	237,5	237,5	240	172	313	403	475	845	104	134
FCS 65-250/185	65	65	119	83	232	237,5	237,5	240	172	313	403	475	845	104	144
FCS 65-250/220	65	65	119	83	232	237,5	237,5	240	172	313	403	475	845	104	154
FCS 80-125/30	80	80	90	90	222	175	185	134	148	174	287	360	610	102	82
FCS 80-125/40	80	80	90	90	222	175	185	154	148	197	293	360	631	102	83
FCS 80-125/55	80	80	90	90	249	175	185	168	148	214	307	360	714	102	86
FCS 80-160/75	80	80	90	90	249	175	185	191	148	256	330	360	706	102	102
FCS 80-200/110	80	80	130	90	248	250	250	191	184	256	354	500	806	112	130
FCS 80-200/150	80	80	130	90	248	250	250	240	184	313	403	500	872	112	140
FCS 80-200/185	80	80	130	90	248	250	250	240	184	313	403	500	872	112	150
FCS 80-200/220	80	80	130	90	248	250	250	240	184	313	403	500	872	112	162
FCS 100-160/110	100	100	105	105	289	225	225	191	172	256	330	450	822	117	135
FCS 100-200/185	100	100	140	105	259	275	275	240	196	313	406	550	893	129	190
FCS 100-200/220	100	100	140	105	259	275	275	240	196	313	406	550	893	129	202

fc_fcs-2p50-en_f_td

FCS4 SERIES

Dimensions and weights at 50 Hz

2

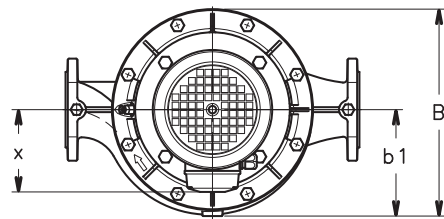
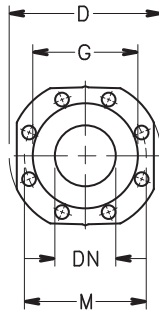
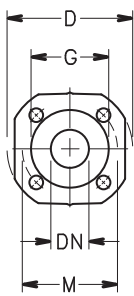
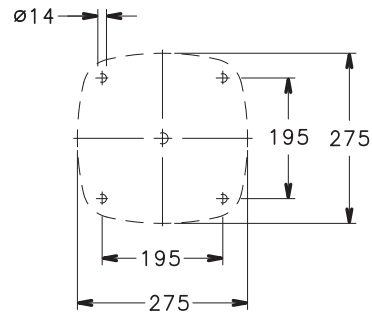
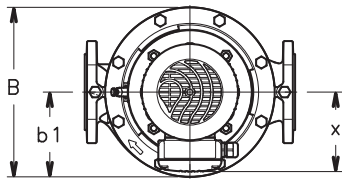
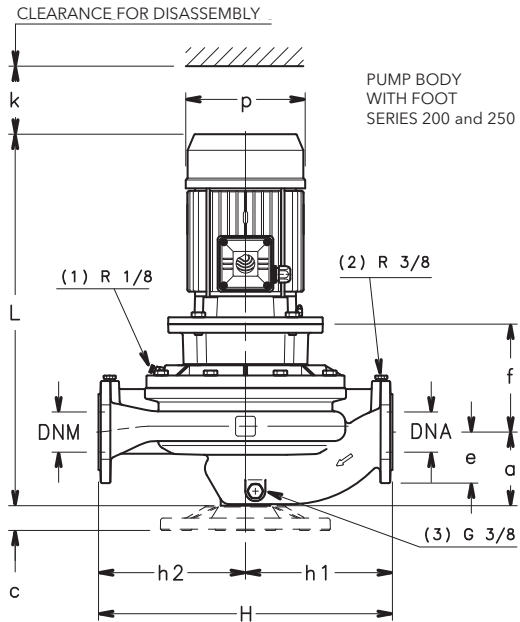
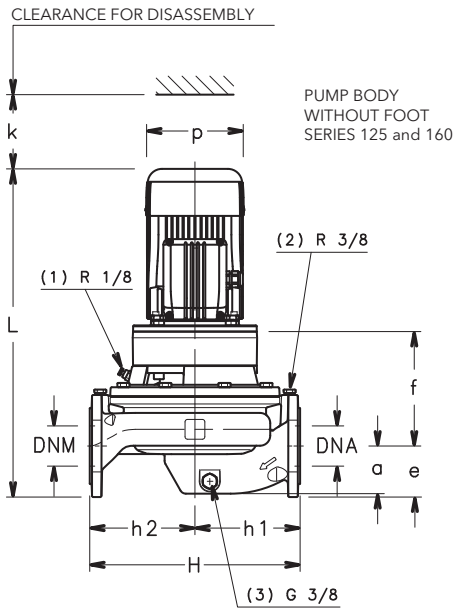

PUMP FLANGES

DN	D	M	G	HOLES		THICKNESS
				Nº	DIA.	MAX.
40	150	110	88	4	18	18
50	165	125	102	4	18	20
65	185	145	122	4	18	20
80	200	160	138	8	18	22
100	220	180	158	8	18	22

- (1) R 1/8 AIR VALVE
- (2) R 3/8 PRESSURE GAUGE CONNECTOR
- (3) G 3/8 GAUGE

04854D_B_DD

FCS4 SERIES

Dimensions and weights at 50 Hz

PUMP TYPE	DIMENSIONS (mm)														WEIGHT
	DNA	DNM	a	e	f	h1	h2	x	b1	p	B	H max	L	k	kg
FCS4 40-200/05	40	40	95	65	155	220	220	129	163	155	325	440	513	98	56
FCS4 40-200/07	40	40	95	65	155	220	220	128	163	159	325	440	481	98	60
FCS4 40-250/11	40	40	95	65	155	220	220	134	163	174	325	440	548	98	67
FCS4 40-250/15	40	40	95	65	155	220	220	134	163	174	325	440	548	98	69
FCS4 50-200/07	50	50	110	73	169	220	220	128	163	159	326	440	510	100	63
FCS4 50-200/11	50	50	110	73	169	220	220	134	163	174	326	440	577	100	72
FCS4 50-250/15	50	50	110	73	169	220	220	134	163	174	326	440	577	100	73
FCS4 50-250/22	50	50	110	73	179	220	220	168	163	214	331	440	611	100	78
FCS4 65-160/07	65	65	77	83	185	170	170	128	137	159	274	340	499	92	49
FCS4 65-160/11	65	65	77	83	185	170	170	134	137	174	274	340	566	92	55
FCS4 65-200/15	65	65	119	83	165	237,5	237,5	134	172	174	335	475	582	104	72
FCS4 65-250/22	65	65	119	83	175	237,5	237,5	168	172	214	335	475	616	104	84
FCS4 65-250/30	65	65	119	83	175	237,5	237,5	168	172	214	335	475	647	104	87
FCS4 80-125/07	80	80	90	90	212	175	185	128	148	159	287	360	533	102	55
FCS4 80-125/11	80	80	90	90	212	175	185	134	148	174	287	360	600	102	66
FCS4 80-200/15	80	80	130	90	181	250	250	134	184	174	347	500	609	112	92
FCS4 80-200/22	80	80	130	90	191	250	250	168	184	214	347	500	643	112	95
FCS4 80-200/30	80	80	130	90	191	250	250	168	184	214	347	500	674	112	97
FCS4 80-250/40	80	80	130	90	191	250	250	168	184	214	347	500	719	112	125
FCS4 80-250/55	80	80	130	90	218	250	250	191	184	256	354	500	753	112	129
FCS4 100-160/15	100	100	105	105	221	225	225	134	172	174	311	450	625	117	78
FCS4 100-200/22	100	100	140	105	202	275	275	168	196	214	362	550	664	129	85
FCS4 100-200/30	100	100	140	105	202	275	275	168	196	214	362	550	695	129	88
FCS4 100-250/40	100	100	140	105	202	275	275	168	196	214	362	550	740	129	140
FCS4 100-250/55	100	100	140	105	229	275	275	191	196	256	362	550	774	129	142
FCS4 100-250/75	100	100	140	105	229	275	275	191	196	256	362	550	774	129	147

fc_fcs4-4p50-en_f_td

Black and white technical books available
see www.lowara.it

FCS4 (125÷150) SERIES
 Dimensions and weights at 50 Hz

2

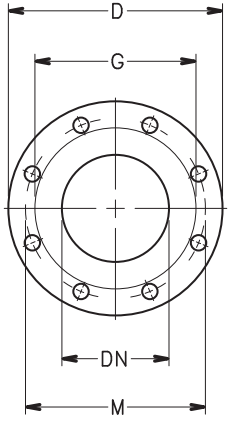
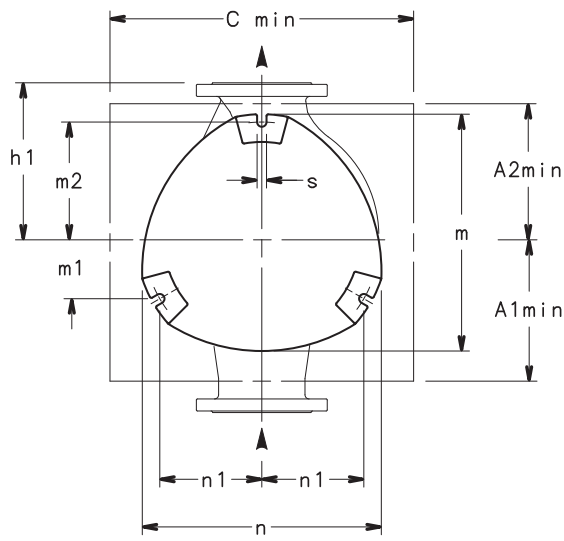
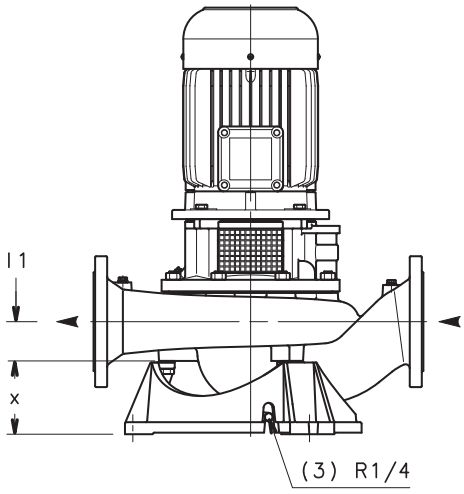
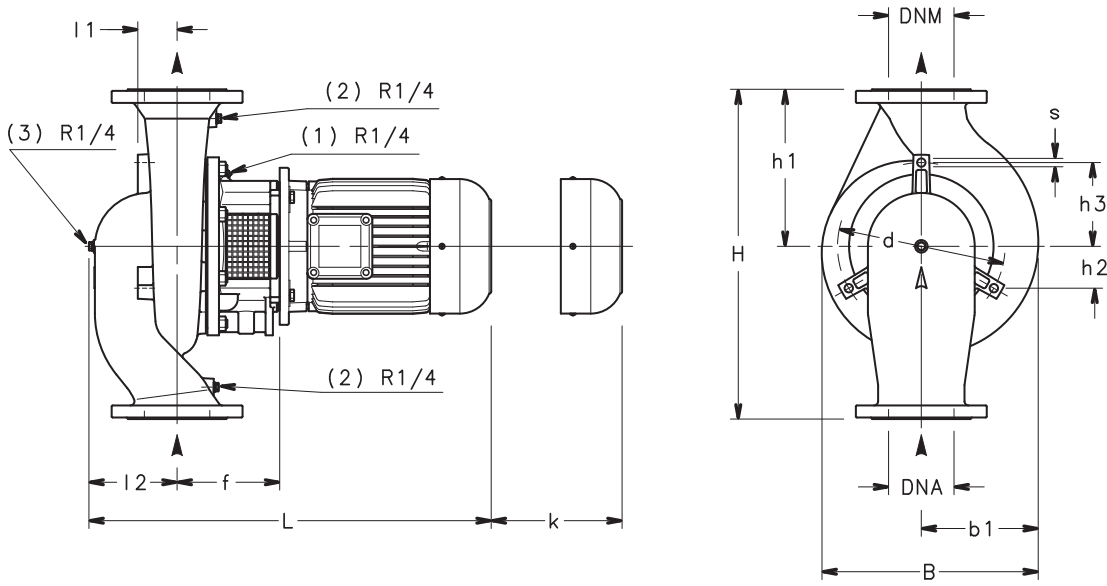

- (1) R 1/4 AIR VALVE
- (2) R 1/4 PRESSURE GAUGE CONNECTOR
- (3) G 1/4 DRAIN

PUMP FLANGES

DN	D	M	G	HOLES		THICKNESS
				N°	DIA.	MAX.
125	250	210	188	8	18	26
150	285	240	212	8	23	26

04852D_A_DD

FCS4 (125÷150) SERIES

Dimensions and weights at 50 Hz

PUMP TYPE	DIMENSIONS (mm) PUMP														WEIGHT
	DNA	DNM	b1	d	f	h1	h2	h3	l1	l2	B	H max	L	k	kg
FCS4 125-160/30	125	125	234	274	196	315	68	137	85	161	418	630	710	143	132
FCS4 125-200/40	125	125	202	274	196	290	68	137	80	164	378	620	758	153	133
FCS4 125-200/55	125	125	202	274	196	290	68	137	80	164	378	620	765	153	154
FCS4 125-250/75	125	125	220	320	196	300	80	160	75	168	422	630	769	150	167
FCS4 125-250/110	125	125	220	320	226	300	80	160	75	168	422	630	888	150	231
FCS4 125-315/150	125	125	262	320	226	350	80	160	130	229	503	775	948	160	298
FCS4 125-315/185	125	125	262	320	226	350	80	160	130	229	503	775	1009	160	334
FCS4 125-315/220	125	125	262	320	226	350	80	160	130	229	503	775	1047	160	356
FCS4 150-200/55	150	150	260	320	211	340	80	160	90	178	468	720	794	160	126
FCS4 150-200/75	150	150	260	320	211	340	80	160	90	178	468	720	794	160	177
FCS4 150-250/110	150	150	276	320	226	365	80	160	85	188	504	755	908	158	255
FCS4 150-250/150	150	150	276	320	226	365	80	160	85	188	504	755	908	158	268
FCS4 150-250/185	150	150	276	320	226	365	80	160	85	188	504	755	968	158	294

PUMP TYPE	DIMENSIONS (mm) SUPPORT FOOT										
	A1	A2	C	m	m1	m2	n	n1	s	x	
FCS4 125-160/30	230	250	480	388	96	192	389	166	M16	120	
FCS4 125-200/40	230	250	480	388	96	192	389	166	M16	120	
FCS4 125-200/55	230	250	480	388	96	192	389	166	M16	120	
FCS4 125-250/75	270	300	580	453	112	225	457	195	M16	140	
FCS4 125-250/110	270	300	580	453	112	225	457	195	M16	140	
FCS4 125-315/150	270	300	580	453	112	225	457	195	M16	140	
FCS4 125-315/185	270	300	580	453	112	225	457	195	M16	140	
FCS4 125-315/220	270	300	580	453	112	225	457	195	M16	140	
FCS4 150-200/55	270	300	580	453	112	225	457	195	M16	140	
FCS4 150-200/75	270	300	580	453	112	225	457	195	M16	140	
FCS4 150-250/110	270	300	580	453	112	225	457	195	M16	140	
FCS4 150-250/150	270	300	580	453	112	225	457	195	M16	140	
FCS4 150-250/185	270	300	580	453	112	225	457	195	M16	140	

lmr_fcs4-4p50-en_d_td

FCTE SERIES

Dimensions and weights at 50 Hz

2

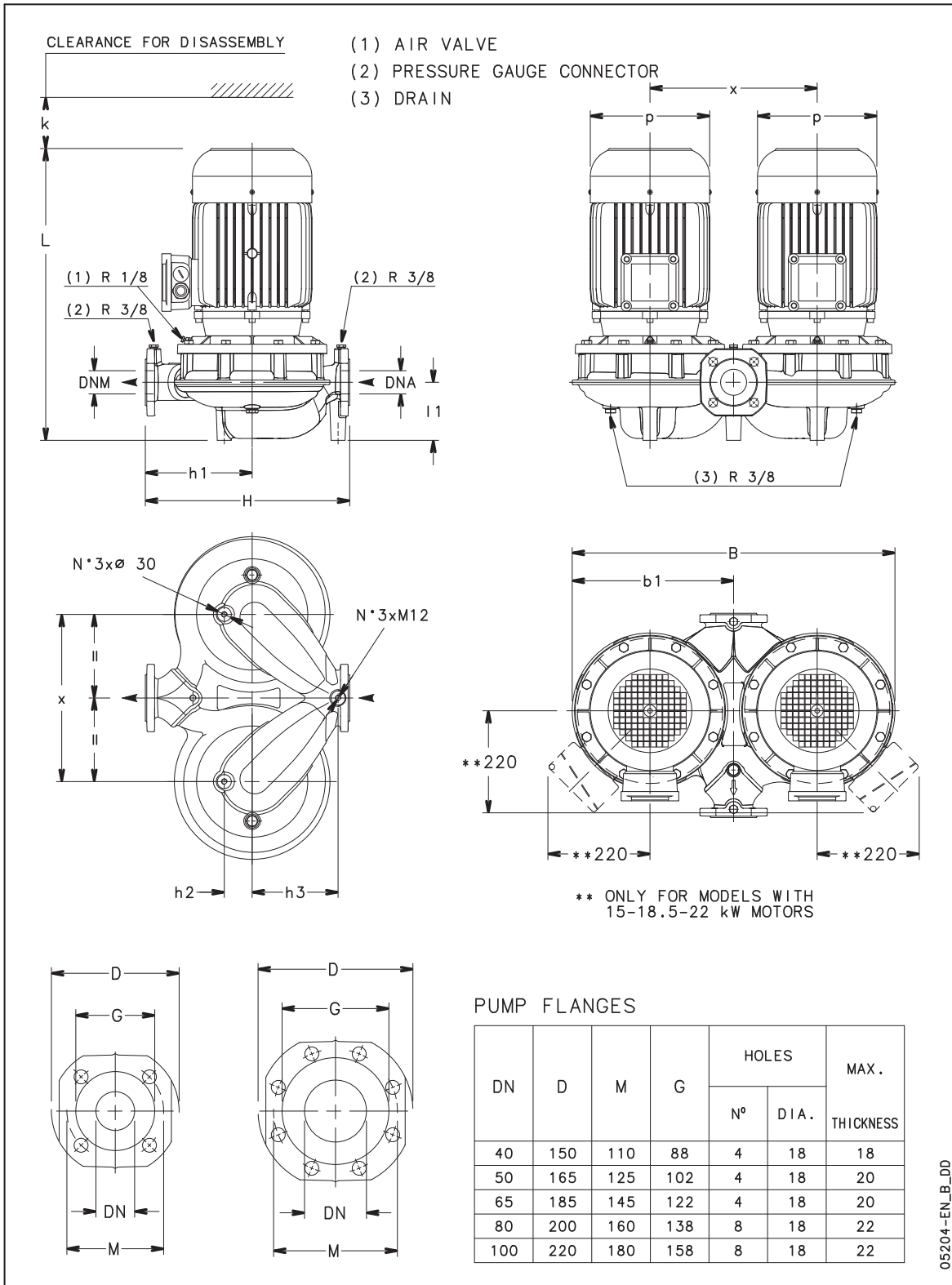

05204-EN_B_DD

FCTE SERIES

Dimensions and weights at 50 Hz

PUMP TYPE	DIMENSIONS (mm)													WEIGHT
	DNA	DNM	b1	h1	h2	h3	l1	p	x	B	H	L	k	kg
FCTE 40-125/07	40	40	245	170	50	120	89	155	250	490	320	452	90	59
FCTE 40-125/11	40	40	245	170	50	120	89	155	250	490	320	452	90	61
FCTE 40-160/15	40	40	245	170	50	120	89	174	250	490	320	487	90	67
FCTE 40-160/22	40	40	245	170	50	120	89	174	250	490	320	487	90	69
FCTE 40-200/40A	40	40	348	220	50	190	97	197	360	695	440	516	101	139
FCTE 40-200/40	40	40	348	220	50	190	97	197	360	695	440	516	101	139
FCTE 40-200/55	40	40	348	220	50	190	97	214	360	695	440	550	101	141
FCTE 40-250/75	40	40	348	220	50	190	97	256	360	695	440	564	101	177
FCTE 40-250/110	40	40	348	220	50	190	97	256	360	695	440	602	101	179
FCTE 50-125/11	50	50	250	180	55	130	92	155	260	500	340	457	91	60
FCTE 50-125/15	50	50	250	180	55	130	92	174	260	500	340	492	91	70
FCTE 50-160/22	50	50	250	180	55	130	92	174	260	500	340	492	91	82
FCTE 50-160/30	50	50	250	180	55	130	92	174	260	500	340	491	91	85
FCTE 50-160/40	50	50	250	180	55	130	92	197	260	500	340	512	91	91
FCTE 50-200/55	50	50	348	230	60	185	125	214	360	695	440	578	110	108
FCTE 50-200/75	50	50	348	230	60	185	125	256	360	695	440	592	110	140
FCTE 50-250/92	50	50	348	230	60	185	125	256	360	695	440	630	110	198
FCTE 50-250/110	50	50	348	230	60	185	125	256	360	695	440	630	110	210
FCTE 50-250/150	50	50	348	230	60	185	125	313	360	695	440	719	110	226
FCTE 65-125/22	65	65	297	185	55	125	108	174	310	593	340	509	96	108
FCTE 65-125/30	65	65	297	185	55	125	108	174	310	593	340	509	96	113
FCTE 65-125/40	65	65	297	185	55	125	108	197	310	593	340	530	96	121
FCTE 65-160/55	65	65	297	185	55	125	108	214	310	593	340	564	96	137
FCTE 65-160/75	65	65	297	185	55	125	108	256	310	593	340	578	96	171
FCTE 65-200/92	65	65	348	260	59	185	130	256	360	695	475	635	109	202
FCTE 65-200/110	65	65	348	260	59	185	130	256	360	695	475	635	109	216
FCTE 65-250/150	65	65	348	260	59	185	130	313	360	695	475	724	109	248
FCTE 65-250/185	65	65	348	260	59	185	130	313	360	695	475	724	109	252
FCTE 65-250/220	65	65	348	260	59	185	130	313	360	695	475	724	109	272
FCTE 80-125/30	80	80	304	210	70	110	141	174	320	607	400	548	106	127
FCTE 80-125/40	80	80	304	210	70	110	141	197	320	607	400	569	106	133
FCTE 80-125/55	80	80	304	210	70	110	141	214	320	607	400	603	106	137
FCTE 80-160/75	80	80	304	210	70	110	141	256	320	607	400	617	106	169
FCTE 80-200/110	80	80	368	280	80	140	157	256	380	722	500	662	112	231
FCTE 80-200/150	80	80	368	280	80	140	157	313	380	722	500	751	112	251
FCTE 80-200/185	80	80	368	280	80	140	157	313	380	722	500	751	112	271
FCTE 80-200/220	80	80	368	280	80	140	157	313	380	722	500	751	112	295
FCTE 100-160/110	100	100	340	270	72	150	175	256	360	670	500	681	118	252
FCTE 100-200/185	100	100	408	310	80	150	180	313	410	798	550	774	128	363
FCTE 100-200/220	100	100	408	310	80	150	180	313	410	798	550	774	128	387

fc_fcte-2p50_c_td

FCTE4 SERIES

Dimensions and weights at 50 Hz

PUMP TYPE	DIMENSIONS (mm)													WEIGHT
	DNA	DNM	b1	h1	h2	h3	l1	p	x	B	H	L	k	kg
FCTE4 40-125/02A	40	40	245	170	50	120	89	140	250	490	320	420	90	46
FCTE4 40-125/02	40	40	245	170	50	120	89	140	250	490	320	420	90	46
FCTE4 40-160/02	40	40	245	170	50	120	89	140	250	490	320	420	90	48
FCTE4 40-160/03	40	40	245	170	50	120	89	140	250	490	320	420	90	50
FCTE4 40-200/05	40	40	348	220	50	190	97	155	360	695	440	460	101	83
FCTE4 40-200/07	40	40	348	220	50	190	97	159	360	695	440	428	101	86
FCTE4 40-250/11	40	40	348	220	50	190	97	174	360	695	440	495	101	123
FCTE4 40-250/15	40	40	348	220	50	190	97	174	360	695	440	495	101	125
FCTE4 50-125/02	50	50	250	180	55	130	92	140	260	500	340	425	91	49
FCTE4 50-125/03	50	50	250	180	55	130	92	140	260	500	340	425	91	51
FCTE4 50-160/05	50	50	250	180	55	130	92	155	260	500	340	457	91	53
FCTE4 50-200/07	50	50	348	230	60	185	125	159	360	695	440	456	110	105
FCTE4 50-200/11	50	50	348	230	60	185	125	174	360	695	440	523	110	122
FCTE4 50-250/15	50	50	348	230	60	185	125	174	360	695	440	523	110	128
FCTE4 50-250/22	50	50	348	230	60	185	125	214	360	695	440	547	110	140
FCTE4 65-125/03	65	65	297	185	55	125	108	140	310	593	340	442	96	75
FCTE4 65-125/05	65	65	297	185	55	125	108	155	310	593	340	474	96	83
FCTE4 65-160/07	65	65	297	185	55	125	108	159	310	593	340	442	96	94
FCTE4 65-160/11	65	65	297	185	55	125	108	174	310	593	340	509	96	107
FCTE4 65-200/15	65	65	348	260	59	185	130	174	360	695	475	528	109	130
FCTE4 65-250/22	65	65	348	260	59	185	130	214	360	695	475	552	109	152
FCTE4 65-250/30	65	65	348	260	59	185	130	214	360	695	475	583	109	156
FCTE4 80-125/07	80	80	304	210	70	110	141	159	320	607	400	481	106	101
FCTE4 80-125/11	80	80	304	210	70	110	141	174	320	607	400	548	106	116
FCTE4 80-200/15	80	80	368	280	80	140	157	174	380	722	500	555	112	153
FCTE4 80-200/22	80	80	368	280	80	140	157	214	380	722	500	579	112	165
FCTE4 80-200/30	80	80	368	280	80	140	157	214	380	722	500	610	112	173
FCTE4 80-250/40	80	80	368	280	80	140	157	214	380	722	500	655	112	225
FCTE4 80-250/55	80	80	368	280	80	140	157	256	380	722	500	662	112	241
FCTE4 100-160/15	100	100	340	270	72	150	175	174	360	670	500	574	118	146
FCTE4 100-200/22	100	100	408	310	80	150	180	214	410	798	550	602	128	201
FCTE4 100-200/30	100	100	408	310	80	150	180	214	410	798	550	633	128	205
FCTE4 100-250/40	100	100	408	310	80	150	180	214	410	798	550	678	128	253
FCTE4 100-250/55	100	100	408	310	80	150	180	256	410	798	550	685	128	265
FCTE4 100-250/75	100	100	408	310	80	150	180	256	410	798	550	685	128	285

fc_fcte4-4p50-en_c_td

FCTS SERIES

Dimensions and weights at 50 Hz

2

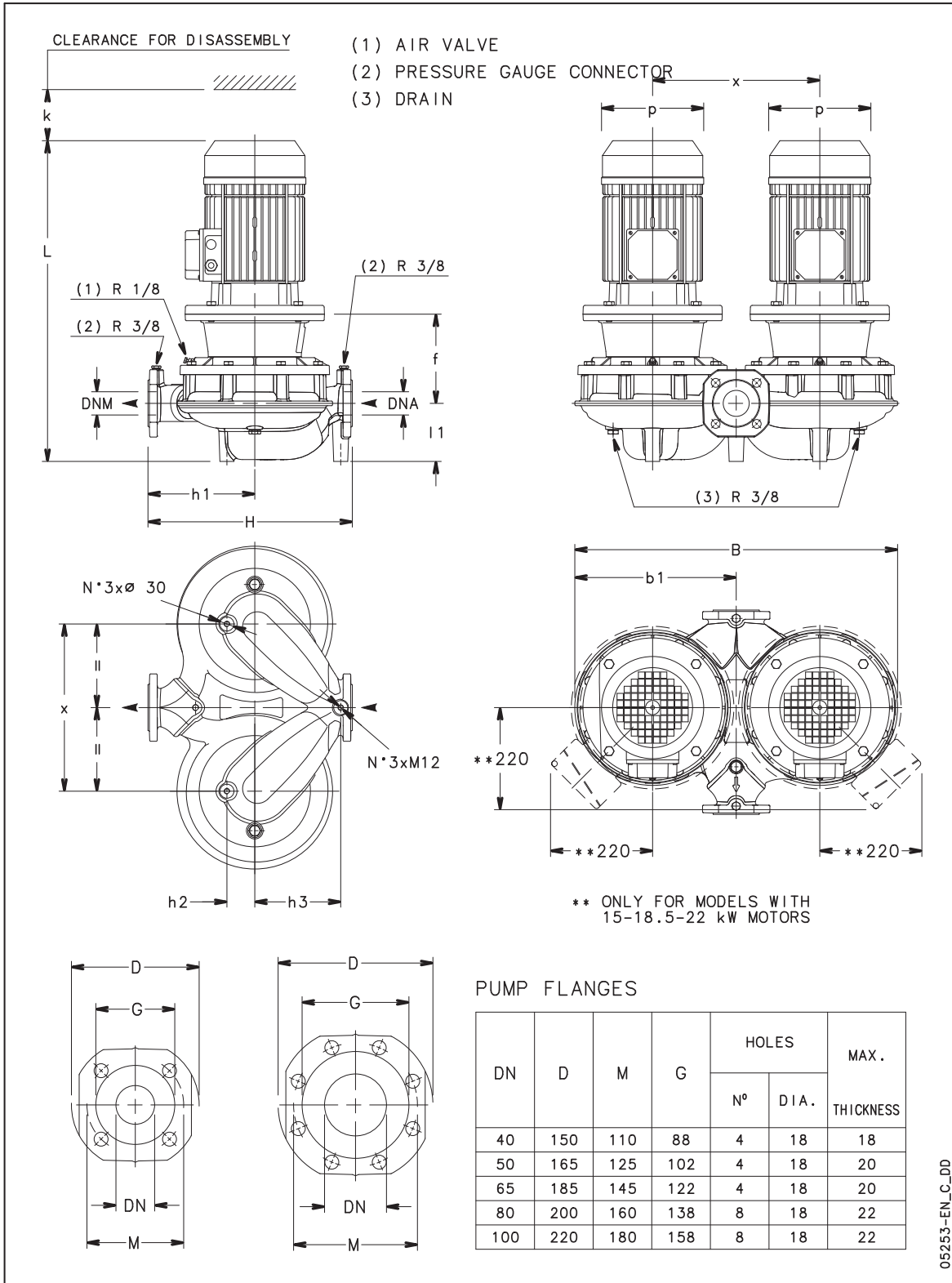

FCTS SERIES

Dimensions and weights at 50 Hz

PUMP TYPE	DIMENSIONS (mm)											WEIGHT			
	DNA	DNM	b1	f	h1	h2	h3	l1	p	x	B	H	L	k	kg
FCTS 40-125/07	40	40	245	155	170	50	120	89	155	250	490	320	507	90	65
FCTS 40-125/11	40	40	245	155	170	50	120	89	155	250	490	320	507	90	67
FCTS 40-160/15	40	40	245	155	170	50	120	89	174	250	490	320	542	90	73
FCTS 40-160/22	40	40	245	155	170	50	120	89	174	250	490	320	542	90	77
FCTS 40-200/30	40	40	348	165	220	50	190	97	174	360	695	440	560	101	133
FCTS 40-200/40	40	40	348	165	220	50	190	97	197	360	695	440	581	101	145
FCTS 40-200/55	40	40	348	192	220	50	190	97	214	360	695	440	664	101	171
FCTS 40-250/75	40	40	348	192	220	50	190	97	256	360	695	440	656	101	207
FCTS 40-250/110	40	40	348	222	220	50	190	97	256	360	695	440	747	101	235
FCTS 50-125/11	50	50	250	156	180	55	130	92	155	260	500	340	511	91	70
FCTS 50-125/15	50	50	250	156	180	55	130	92	174	260	500	340	546	91	78
FCTS 50-160/22	50	50	250	156	180	55	130	92	174	260	500	340	546	91	94
FCTS 50-160/30	50	50	250	166	180	55	130	92	174	260	500	340	556	91	95
FCTS 50-160/40	50	50	250	166	180	55	130	92	197	260	500	340	577	91	109
FCTS50-200/55	50	50	348	192	230	60	185	125	214	360	695	440	692	110	178
FCTS 50-200/75	50	50	348	192	230	60	185	125	256	360	695	440	684	110	212
FCTS 50-250/110A	50	50	348	222	230	60	185	125	256	360	695	440	775	110	226
FCTS 50-250/110	50	50	348	222	230	60	185	125	256	360	695	440	775	110	226
FCTS 50-250/150	50	50	348	222	230	60	185	125	313	360	695	440	841	110	246
FCTS 65-125/22	65	65	297	158	185	55	125	108	174	310	593	340	564	96	138
FCTS 65-125/30	65	65	297	168	185	55	125	108	174	310	593	340	574	96	123
FCTS 65-125/40	65	65	297	168	185	55	125	108	197	310	593	340	595	96	133
FCTS 65-160/55	65	65	297	195	185	55	125	108	214	310	593	340	678	96	159
FCTS 65-160/75	65	65	297	195	185	55	125	108	256	310	593	340	670	96	189
FCTS 65-200/110A	65	65	348	222	260	59	185	130	256	360	695	475	780	109	258
FCTS 65-200/110	65	65	348	222	260	59	185	130	256	360	695	475	780	109	258
FCTS 65-250/150	65	65	348	222	260	59	185	130	313	360	695	475	846	109	260
FCTS 65-250/185	65	65	348	222	260	59	185	130	313	360	695	475	846	109	272
FCTS 65-250/220	65	65	348	222	260	59	185	130	313	360	695	475	846	109	292
FCTS 80-125/30	80	80	304	174	210	70	110	141	174	320	607	400	613	106	162
FCTS 80-125/40	80	80	304	174	210	70	110	141	197	320	607	400	634	106	164
FCTS 80-125/55	80	80	304	201	210	70	110	141	214	320	607	400	717	106	170
FCTS 80-160/75	80	80	304	201	210	70	110	141	256	320	607	400	709	106	202
FCTS 80-200/110	80	80	368	222	280	80	140	157	256	380	722	500	807	112	251
FCTS 80-200/150	80	80	368	222	280	80	140	157	313	380	722	500	873	112	271
FCTS 80-200/185	80	80	368	222	280	80	140	157	313	380	722	500	873	112	291
FCTS 80-200/220	80	80	368	222	280	80	140	157	313	380	722	500	873	112	315
FCTS 100-160/110	100	100	340	223	270	72	150	175	256	360	670	500	826	118	268
FCTS 100-200/185	100	100	408	222	310	80	150	180	313	410	798	550	896	128	384
FCTS 100-200/220	100	100	408	222	310	80	150	180	313	410	798	550	896	128	407

fc_fcts-2p50-en_c_td

FCTS4 SERIES

Dimensions and weights at 50 Hz

2

CLEARANCE FOR DISASSEMBLY

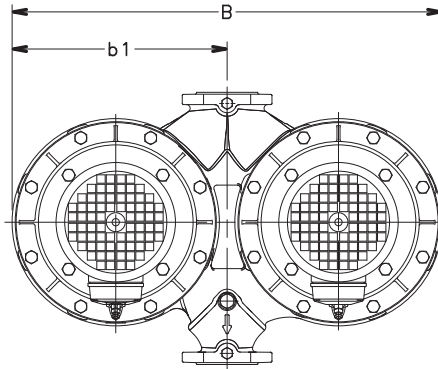
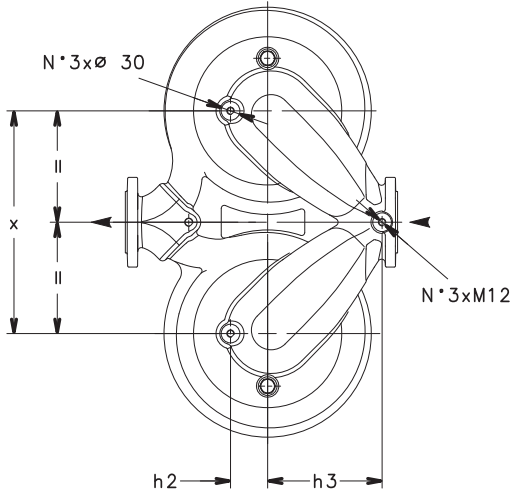
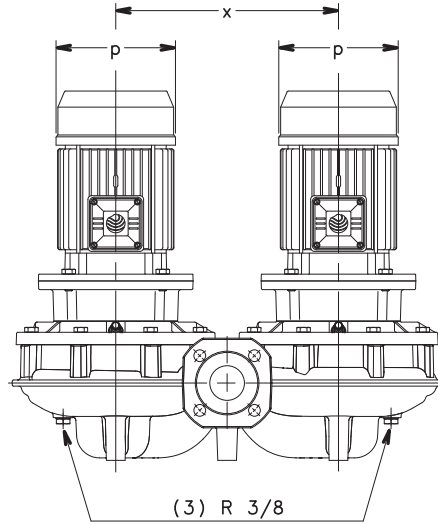
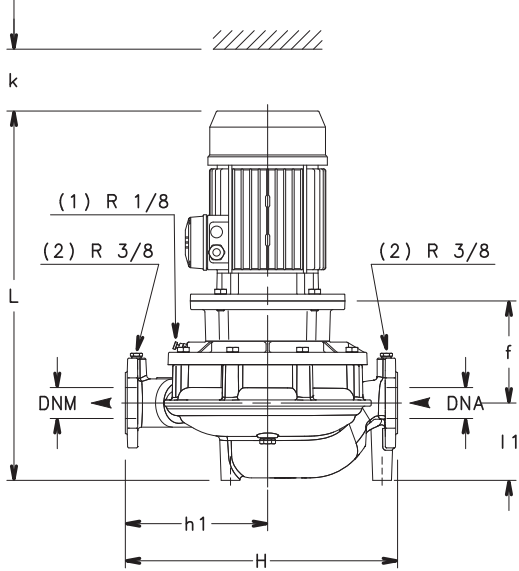

- (1) AIR VALVE
- (2) PRESSURE GAUGE CONNECTOR
- (3) DRAIN

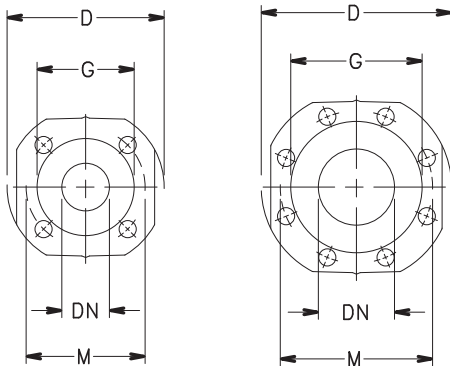

PUMP FLANGES

DN	D	M	G	HOLES		THICKNESS MAX.
				Nº	DIA.	
40	150	110	88	4	18	18
50	165	125	102	4	18	20
65	185	145	122	4	18	20
80	200	160	138	8	18	22
100	220	180	158	8	18	22

05254_A_DD

FCTS4 SERIES

Dimensions and weights at 50 Hz

PUMP TYPE	DIMENSIONS (mm)											WEIGHT			
	DNA	DNM	b1	f	h1	h2	h3	l1	p	x	B	H max	L	k	kg
FCTS4 40-200/05	40	40	348	155	220	50	190	97	155	360	695	440	515	101	107
FCTS4 40-200/07	40	40	348	155	220	50	190	97	159	360	695	440	483	101	116
FCTS4 40-250/11	40	40	348	155	220	50	190	97	174	360	695	440	550	101	129
FCTS4 40-250/15	40	40	348	155	220	50	190	97	174	360	695	440	550	101	133
FCTS4 50-200/07	50	50	348	155	230	60	185	125	159	360	695	440	511	110	123
FCTS4 50-200/11	50	50	348	155	230	60	185	125	174	360	695	440	578	110	140
FCTS4 50-250/15	50	50	348	155	230	60	185	125	174	360	695	440	578	110	142
FCTS4 50-250/22	50	50	348	165	230	60	185	125	214	360	695	440	612	110	152
FCTS4 65-160/07	65	65	297	158	185	55	125	108	159	310	593	340	497	96	98
FCTS4 65-160/11	65	65	297	158	185	55	125	108	174	310	593	340	564	96	109
FCTS4 65-200/15	65	65	348	155	260	59	185	130	174	360	695	475	583	109	136
FCTS4 65-250/22	65	65	348	165	260	59	185	130	214	360	695	475	617	109	160
FCTS4 65-250/30	65	65	348	165	260	59	185	130	214	360	695	475	648	109	166
FCTS4 80-125/07	80	80	304	164	210	70	110	141	159	320	607	400	536	106	109
FCTS4 80-125/11	80	80	304	164	210	70	110	141	174	320	607	400	603	106	130
FCTS4 80-200/15	80	80	368	155	280	80	140	157	174	380	722	500	610	112	175
FCTS4 80-200/22	80	80	368	165	280	80	140	157	214	380	722	500	644	112	181
FCTS4 80-200/30	80	80	368	165	280	80	140	157	214	380	722	500	675	112	185
FCTS4 80-250/40	80	80	368	165	280	80	140	157	214	380	722	500	720	112	241
FCTS4 80-250/55	80	80	368	192	280	80	140	157	256	380	722	500	754	112	249
FCTS4 100-160/15	100	100	340	156	270	72	150	175	174	360	670	500	629	118	154
FCTS4 100-200/22	100	100	408	165	310	80	150	180	214	410	798	550	667	128	173
FCTS4 100-200/30	100	100	408	165	310	80	150	180	214	410	798	550	698	128	179
FCTS4 100-250/40	100	100	408	165	310	80	150	180	214	410	798	550	743	128	283
FCTS4 100-250/55	100	100	408	192	310	80	150	180	256	410	798	550	777	128	287
FCTS4 100-250/75	100	100	408	192	310	80	150	180	256	410	798	550	777	128	297

fc_fcts4-4p50-en_d_td



FCTS4 (125÷150) SERIES

Dimensions and weights at 50 Hz

2

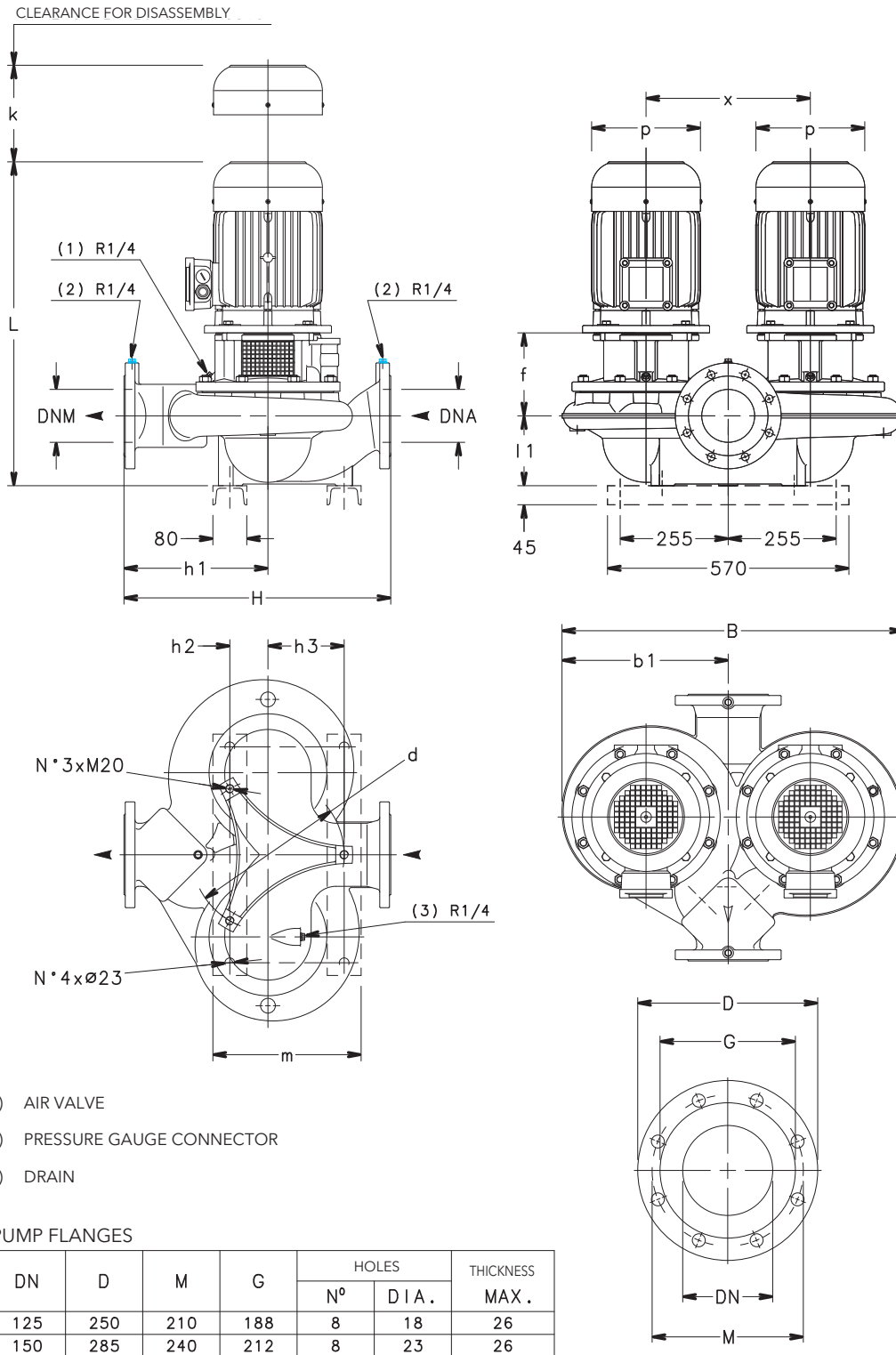

05255_A_DD

FCTS4 (125÷150) SERIES

Dimensions and weights at 50 Hz

PUMP TYPE	PUMP DIMENSIONS (mm)													WEIGHT			
	DNA	DNM	b1	d	f	h ₁	h ₂	h ₃	l ₁	m	p	x	B	H	L	k	kg
FCTS4 125-160/30	125	125	422	360	196	350	90	180	175	350	214	386	800	630	724	143	254
FCTS4 125-200/40	125	125	368	360	196	330	90	180	160	350	214	349	716	620	754	153	252
FCTS4 125-200/55	125	125	368	360	196	330	90	180	160	350	256	349	716	620	761	153	294
FCTS4 125-250/75	125	125	412	360	196	340	90	180	165	350	256	388	805	630	766	150	325
FCTS4 125-250/110	125	125	412	360	226	340	90	180	165	350	313	388	805	630	885	150	453
FCTS4 150-200/55	150	150	471	460	211	400	115	230	175	425	256	440	900	720	791	160	356
FCTS4 150-200/75	150	150	471	460	211	400	115	230	175	425	256	440	900	720	791	160	350
FCTS4 150-250/110	150	150	498	460	226	405	115	230	200	425	313	466	963	755	920	158	532
FCTS4 150-250/150	150	150	498	460	226	405	115	230	200	425	313	466	963	755	920	158	538
FCTS4 150-250/185	150	150	498	460	226	405	115	230	200	425	360	466	963	755	980	158	610

lmz_fcts4-4p50-en_d_td